



Radiant Systems

Catalog
01/2022 ITALIA

ER0001  FEB2022



**Radiant
floor
systems**

Catalog

Radiant floor systems

Check **sales terms and conditions** (delivery schedule, freight costs) with our Sales Area Manager.

For the **general sales conditions and warranty** make reference to the general ***Catalog Price List Italy*** in force or visit it.giacomini.com/informazioni-legali.

The information, specifications and prices of products included in this catalog shall not bind Giacomini S.p.A. in any way in case of technical and commercial modifications or printing mistakes.

Copy, also in part, of the catalog contents is forbidden, unless written authorization by Giacomini's Administration is provided.

EDITION February 2022. **GRAPHIC LAYOUT** Advertendo Srl. **PRINTED BY** Tipolitografia Testori & C. snc.



Introduction 04

CHAPTER 1

Radiant floor basic principles
and benefits 10

CHAPTER 2

Overview of
radiant floor systems by Giacomini 18

CHAPTER 3

Mixing and distribution
manifolds 50

CHAPTER 4

Radiant system
pipes 60

CHAPTER 5

68 Advanced climate
control

CHAPTER 6

90 Cooling
and air treatment

CHAPTER 7

112 Accessories and
other components

CHAPTER 8

124 Regulatory-
compliance installation

THE FUTURE FUELS OUR GROWTH

80 t of brass machined daily, 130 thousand sqm of production plants, 900 employees, a +250 million Euro turnover, 80% of export, branches and business partners in 18 countries worldwide: **our numbers say a lot about us, our customers' satisfaction says it all.**

OUR PASSION NEVER STOPS GROWING. JUST LIKE OUR GROUP.

BELGIUM

Giacomini Benelux S.A.
1301 Bierges (Wavre)
Route provinciale 273-277

CANADA

Giacomini Consulting Canada Inc.
1020-1500 West Georgia Street
VANCOUVER, BC V6G 2Z6

CHINA

Giacomini Heating and Cooling
Technology (Beijing) Co., Ltd
100027 Chaoyang District, Beijing
No. 2 Dong San Huan Bei Lu Bing
B1-12, Business Street, TYG Centre

CZECH REPUBLIC

Giacomini Czech, S.R.O.
46602 Jablonec nad Nisou
Erbenova 15

GERMANY

Giacomini GMBH
51545 Waldbroel
Industriestrasse 10

FRANCE

Giacomini S.A.
77348 Pontault Combault Cedex
Parc de Pontillault
Rue de Rome
CS 30176

INDIA

Giacomini India
Mumbai, Maharastra. G-3, Neel Madhav
400080, V.P. cross road, Mulund (west)
Nr. Navneet Hospital

JORDAN

Giacomini Middle East
P.O. Box: 851439, Amman 11185
Khalda, Amer bin Malik Str. 65, FL2

POLAND

Giacomini Poland
Giacomini Sp. Z O.O.
87-100 Toruń
Ul. Koniuchy 8



Established in 1951 to produce brass components, Giacomini crosses at once the borders of Italy, a country on its way to reconstruction. In the following decade, we set out to conquer the American continent. In the '70s we work hard to provide new integrated systems and not just components. With the technological boost of the '80s, we start producing automatic control devices for air conditioning systems. In late '900 we undertake an unremitting training activity dedicated to the most enterprising installers, distributors and planners.

The new century witnesses the first hydrogen-fueled heat generator turning us into **true pioneers that offer specific solutions for renewable energies.** Today we take on the sustainability challenge thinking out of the box to balance buildings, nature and wellbeing and

provide efficient and comfortable habitats.

In nearly 70 years we have handled almost every type of energy, but we let the most powerful one flow in total freedom: the future, the growth fuel that leads us towards new goals every day.

Italy is our home, with our seats and plants strategically located.

- Seat and brass-machining plant
28017 San Maurizio d'Opaglio
Novara, Via per Alzo, 39
- Plastic material plant
28017 San Maurizio d'Opaglio
Novara, Via Brughiere, 29
- Molding plant
37014 Castelnuovo del Garda
Verona, Via Bisavola, 4

PORTUGAL

Giacomini Portugal
Sistemas Sanitários
e Climatização, LDA.
4485-188 Gião - VCD
Vila do Conte
Rua de Martinhães 263

RUSSIA

Giacomini Russia
107045 Moscow
Daev Pereulok, 20

SLOVAKIA

Giacomini Slovakia S.R.O.
01091 Zilina, Dolné Rudiny 1

SPAIN

Giacomini España S.L.
08553 Seva - Barcelona
Carretera Viladrau, Km 10

SWITZERLAND

Giacomini S.A.
6512 Giubiasco (Ticino)
Via Linoleum 14

TURKEY

Giacomini Unival
Tesisat Armatürleri, San Ve Tic. Ltd
Bulvarı - 2. Sok No:8 Tuzla Istanbul
İstanbul Anadolu Yakası
Organize San. Böl. Gazi

HONG KONG

Giacominil Asia, Pacific limited
Unit A129, 16/F, Sun Life Tower,
The Gateway, Harbour City,
Kowloon, Hong Kong

ENGLAND

Giacomini UK Ltd.
South Gloucestershire
BS37 5YT, Unit 2, Goodrich Close
Westerleigh Business Park Yate

USA

Giacomini USA
Chicago, IL 60604
141 W. Jackson Blvd. Suite 2750





GIACOMINI ACADEMY, A STEP TO THE FUTURE

TRAINING. INNOVATION. CONFRONTATION

In-house training to the client's advantage.

We dedicate special value to our collaborators' skills and professionalism through constant training processes that include updating courses, stages, periodical sessions of technical analysis.

This helps us provide a highly-qualified service to our clients. **Professional training.** Our goal is to make Giacomini Academy a place where our firm and its partners can share and compare ideas, grow and find stimuli for constant improvement.

Our seminars offer an in-depth study of installation aspects while analyzing market trends, cutting-edge technologies as well as law provisions and standards in force.



Giacomini provides all its clients a user-friendly and powerful tool to learn the installation and maintenance procedures for its main products, stay updated and solve the most common issues. Follow us on our YouTube channel GIACOMINI VIDEO PROJECT.





Training customized for every single application.

ENERGY MANAGEMENT

Course describing components for energy consumption optimization. Types of metering (direct and indirect), thermostatic heads, etc..

RADIANT SYSTEMS

The course will analyze basic concepts for thermoregulation of radiant floor and ceiling systems.

WATER MANAGEMENT

In-depth analysis of water distribution systems made with PEX/AL/PEX, PEX, PP-R pipes. Products for fluid shut-off and control, types of fittings.

GAS DISTRIBUTION

Analysis of systems recommended for gas abduction, distribution and shut-off for domestic use.

RENEWABLE SOURCES

Course dedicated to products and systems for renewable energy sources and with low environment impact. Heat pumps, Solar energy, Geothermal energy, Biomasses, etc.

AREAS OF INTERVENTION AND CERTIFICATIONS

WE STAND WITH ENERGY.

We cover multiple areas of intervention thanks to a wide range of skills acquired along the years and acknowledged on a global level. This is well-proven by the certifications we have achieved.

 Energy Management

Components for energy consumption optimization and metering, and for hot and cold fluid distribution.

 Radiant Systems

Radiant floor, wall and ceiling air conditioning for residential and tertiary use, thermoregulation and air treatment.

 Water Management

Components for drinking water distribution lines, devices for domestic water systems.

 Gas Distribution

Distribution products and systems for safe and high-performing gas transfer in buildings.

 Renewable Sources

Components dedicated to renewable-source energy-production systems.

 Hydrogen Systems

Innovative and integrated solutions for eco-friendly hydrogen-fueled heating.

 Fire Protection

Special top-performance components for the fire prevention professional sector.

 Giacomini Certifications

Giacomini S.p.A. relies on an Integrated Management System for Quality, Environment, Workplace Health and Safety certified by ICIM.





RADIANT FLOOR BASIC PRINCIPLES AND BENEFITS

Constant wellbeing. Enhanced living comfort.

Reduced energy impact. Radiant floor systems ensure the ideal climate with an even and healthy temperature and no draughts. Simply put, state-of-the-art climate.

INVISIBLE WELLNESS SYSTEMS

From a strictly technical standpoint, radiant floors are hydronic systems balancing the sensible loads of air conditioned spaces. From a more "functional" and basic perspective, **they provide ideal comfort inside living environments.**

The water flowing through the plastic pipes, which are drowned in the concrete layer, represents the heat transfer fluid that actually turns the entire flooring into an invisible radiant system.

Radiant floors, with their natural simplicity, are but one of man's many successful attempts to translate a spontaneous phenomenon from nature into technology: **thermal exchange** by irradiation. The sun transmits heat to the Earth according to the same mechanism, an effect anyone can recreate by standing in the sun under a blue sky on a winter day: with a 9-10 °C air temperature one just needs a sweater to feel comfortable. And we all know that sweaters of different colors make us feel more or less warm.

This is known as irradiation; we cannot touch the sun and air can only make us feel cold, but the percentage of irradiation heat is higher than the one which cold air takes from us: the general feeling is pleasant. Radiant floors reproduce the same effect.

Radiant systems have experienced a rapid growth thanks to their ability to **heat** while ensuring an ideal temperature distribution. The technological evolution of thermoregulation devices has made them very popular also for summer **cooling** - a winning alternative to air conditioners - thus becoming **reversible systems** to be used for the entire thermal cycle of the residential unit.

Hydronic radiant floors work with a small difference of temperature between water and the room to be heated/cooled, both for winter heating and summer cooling, as well as between the room and the external air: this is why they can be defined **systems with a reduced temperature difference.**

Thermal-hygrometric comfort, energy saving, excellent exploitation of renewable source energy, ideal use of the spaces: these are all beneficial aspects that have made the "invisible system" popular both for new constructions and renovation works.

The next chapters introduce the range of radiant solutions by Giacomini to guide professionals in accurately selecting the most suitable system for new and existing constructions through targeted interventions of energy upgrading.





It has been proven that radiant floors properly sized and realized with modern technologies provide the human body with higher levels of comfort and wellness compared to traditional heating systems (air or radiators): **enhanced comfort with constant and even temperatures in the various rooms.**

Radiant floor systems prevent heat from layering on the ceiling – the same effect caused by the warm and light air molecules ejected from the outlets of traditional systems – offering a feeling of wellness at “man’s level”. The same benefits are directly perceived by the human body inside buildings with high ceilings – churches, industrial warehouses, etc. – thanks to proximity to the floor.

The overall heat transfer is a combination of thermal exchange by convection and thermal exchange by irradiation extended to every surface and individual inside a room.

The availability of air at an even temperature in the room volume prevents annoying convective draughts which cause dust circulation, an effect typical of units heated with traditional systems. Furthermore, the reduced temperature difference between the floor and the environment minimizes the natural convective phenomena, thus reducing the presence of dust and, as a consequence, the bacteria it carries. The **operating temperature T_{op}** assesses the

convective and irradiation thermal exchanges with a single index, as the arithmetic mean between the air temperature T_a and the mean temperature of all the radiant surfaces surrounding the environment T_s : T_{op} is however the temperature that our body actually perceives inside the room.

Picture 1.2 shows how the wide radiant surface of the floor provides irradiation systems an air temperature T_a lower than convective systems but with the same T_{op} . This prevents the foul air effect we often perceive when entering overheated rooms. Less warm air is also less dry, and this helps the respiratory system to work properly by preventing inflammations of the nasal mucosa as well as laryngitis and bronchitis.

The same principles of heating comfort apply to cooling: the purpose is to effectively control temperature and humidity while preventing draughts. The most efficient solution to achieve thermal comfort in summer, in terms of energy saving and final result, is represented by radiant floors combined to specifically designed **dehumidification machines**. This thermoregulation strategy is quite basic: cooling radiant floors lower the temperature by getting rid of the sensible thermal loads, while dehumidification systems reduce the level of humidity by balancing the latent thermal loads, generally high in summer due to external conditions and human activity.

HIGH-EFFICIENCY AND ENERGY SAVING

As described above, the effect of hydronic radiant floors on the operating temperature perceived by the user turns them into **systems with a reduced temperature difference.**

The small difference between the air temperature of the conditioned room and the external air enables to **cut down heat dispersions (or recirculation)** and achieve major energy saving in full compliance with the new regulations in force.

The surface temperature of the radiant floor, strictly connected to the temperature of the delivery water flowing through the pipes, is enhanced by the irradiation thermal-exchange mechanism which raises it to the power of four. This is why radi-

ant systems support water at 15 °C when cooling and at 35 °C when heating. On the contrary, traditional systems – in which thermal exchange only or generally takes place by convection – require water at 6-7 °C when cooling and at 50-60 °C when heating. As a consequence, delivery temperatures typical of radiant systems offer greater energy saving rates and enable to exploit energy sources with a higher efficiency (solar panels, heat pumps, condensing boilers).

Last but not least, worth noting is that water has a higher thermal capacity compared to air thus providing higher efficiency when distributing the same quantity of heat in hydronic systems: this reduces the costs of



1.2

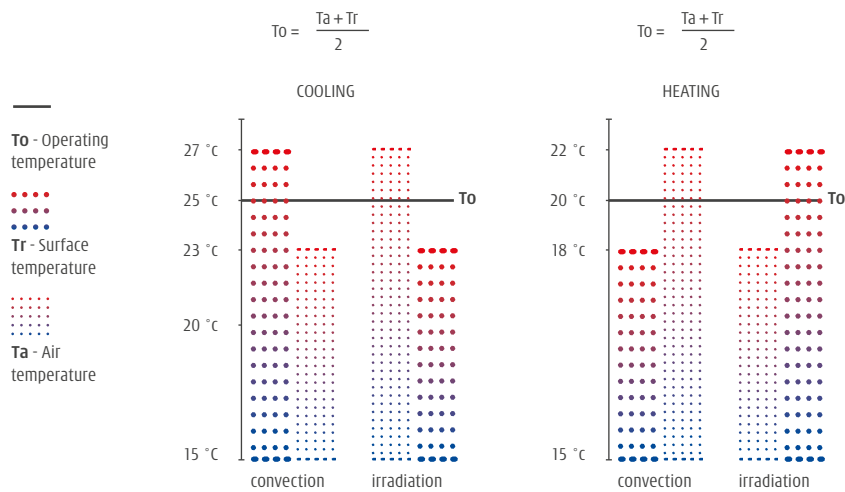

electric energy consumed by air-only system fans. Radiant heating and cooling systems, with their high yield and low consumptions, are therefore the ideal

solution to **increase the energy efficiency** of the building-installation system and achieve the highest rates for energy efficiency classes.

THE ULTIMATE DECORATION FREEDOM WITH NO AESTHETICAL LIMIT

Flexibility of the living space and total freedom of decoration are by now essential requirements in modern residential units. Radiant floor systems put no limit to interior decoration creativity, **eliminating any functional and aesthetic barrier** of traditional air conditioning units (radiators, fan coils).

These units take up volume: their overall dimensions, the distance required for proper functioning and adequate distance of comfort

for users. Radiant floors do not take up space in the room and on walls: their great economic benefit as air conditioning system is also proven by the square meters actually exploitable. Radiant floors are also the perfect solution for historical buildings where the installation of exposed heating units are not an option for explicit constraints or architectonic choices: the original project remains unaltered, ensuring an impeccable aesthetic result.

NOISELESS AND STATE-OF-THE-ART SOUNDPROOFING

The low speeds of the water flowing through the synthetic pipes guarantee a **noiseless** performance. In addition, the insulation panels

of the radiant system have a **sound-absorbing** surface which reduces the noise from other floors and the trampling acoustic pressure.



LONG LASTING AND LIMITED MAINTENANCE

All components of the system feature an extended duration, generally longer than the useful life of the building. The plastic pipes used in distribution loops do not break or crack for corrosion. The insulation panels under the radiant screed, made in crossed-linked expanded polystyrene and lined with a protective layer, are not subject to installation stress or environmental phenomena.

Neither the other components require specific care as they have very few mechanical parts that may be affected by wear and tear. In addition, as opposed to traditional radiators and fan coil units which require regular cleaning and painting (including the adjoining walls), the radiant system invisible terminal – the floor itself – requires no intervention.

EFFICIENCY-ORIENTED AND FLEXIBLE PLANNING

Planning represents the most important step of construction projects: the energy efficiency level depends by large on the construction techniques provided upon planning and on the materials selected. In addition to smart planning solutions (orientation of the building to enhance the solar energy contribution, technique and construction materials), the building must have **highly efficient and perfectly integrated systems**.

The radiant system heating and cooling capacity is determined by various factors: performance of the insulation layer; minimum and maximum limit temperatures; mechanisms of thermal exchange between piping water and floor and between the floor and the room; temperature and humidity control. The maximum and minimum limit temperatures for the internal surfaces are defined by comfort and surface moisture. Technical regulations (UNI EN 1264) are provided to define the radiant floor maximum temperature for heating (29 °C for the occupied zone, 35 °C for perimetrical zones featuring a 20 °C air temperature). For cooling instead, one must consider that a surface colder than the room dew temperature will present a layer of moisture, an effect which must be prevented. That is why the floor must maintain a temperature higher than the dew temperature at all times and never drop under 19 °C to prevent discomfort.

Thermal exchange mechanisms are affected by the following variables:

- pipe pitch: the closer the pipes, the greater the thermal exchange efficiency as the surface near the pipe is more affected by the water temperature;
- pipe conductivity: by now mostly made in plastic, a material that guarantees great reliability on a long term, these pipes have a reduced cost compared to metals, they are not affected by corrosion and offer great installation versatility;
- concrete screed: the pipes must be properly fitted to the conductive layer. By now the market offers screeds specifically designed for radiant installations and featuring excellent fluidity, high conductivity and reduced thermal inertia;
- coating material: the choice between more insulating (e.g. wood) or more conductive materials (e.g. ceramic) will influence the radiant system planning and management, yet without compromising its efficiency.

The radiant system performance depends largely on the **thermal insulation layer** used to limit heat dispersions between the pipes and the background environment. The thermal resistance limits of heating/cooling combined systems are defined by law (UNI EN 1264-4, see fig. 1.3) according to the temperature of the adjoining room or the one below. Thermal resistance depends on the thermal conductivity of the material, thickness, temperature and humidity under regular use conditions.



1.3

Minimum insulation requirements in compliance with standard UNI EN 1264-4. Thermal resistance.

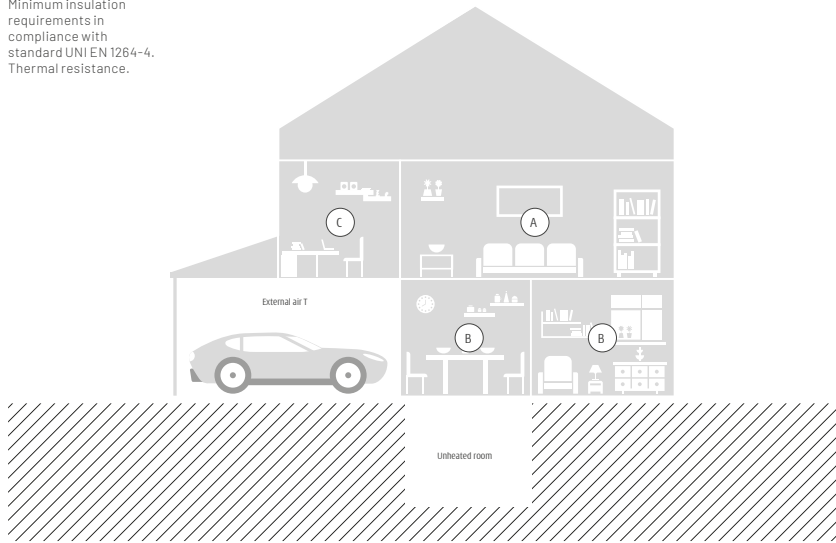
**INSULATION CASE A**

Heated room below.

$$R \geq 0,75 \text{ m}^2 \text{ K} / \text{W}$$

INSULATION CASE B

Unheated room below

or not insulated from the ground.

$$R \geq 1,25 \text{ m}^2 \text{ K} / \text{W}$$

INSULATION CASE C

Room in contact with external air.

Project external air temperature:

$$-5^\circ \text{C} > T_{\text{external air}} \geq -15^\circ \text{C}.$$

$$R \geq 2,00 \text{ m}^2 \text{ K} / \text{W}$$

KLIMABUS BENEFITS

Ideal comfort



One single system for heating and cooling



High-efficiency and energy saving



The utmost decoration freedom with no aesthetic limits



Noiseless and ideal soundproofing



OVERVIEW OF RADIANT FLOOR SYSTEMS BY GIACOMINI

The ultimate efficiency and comfort for new constructions and renovation works.

We offer cutting-edge solutions to install radiant floors in every living context.

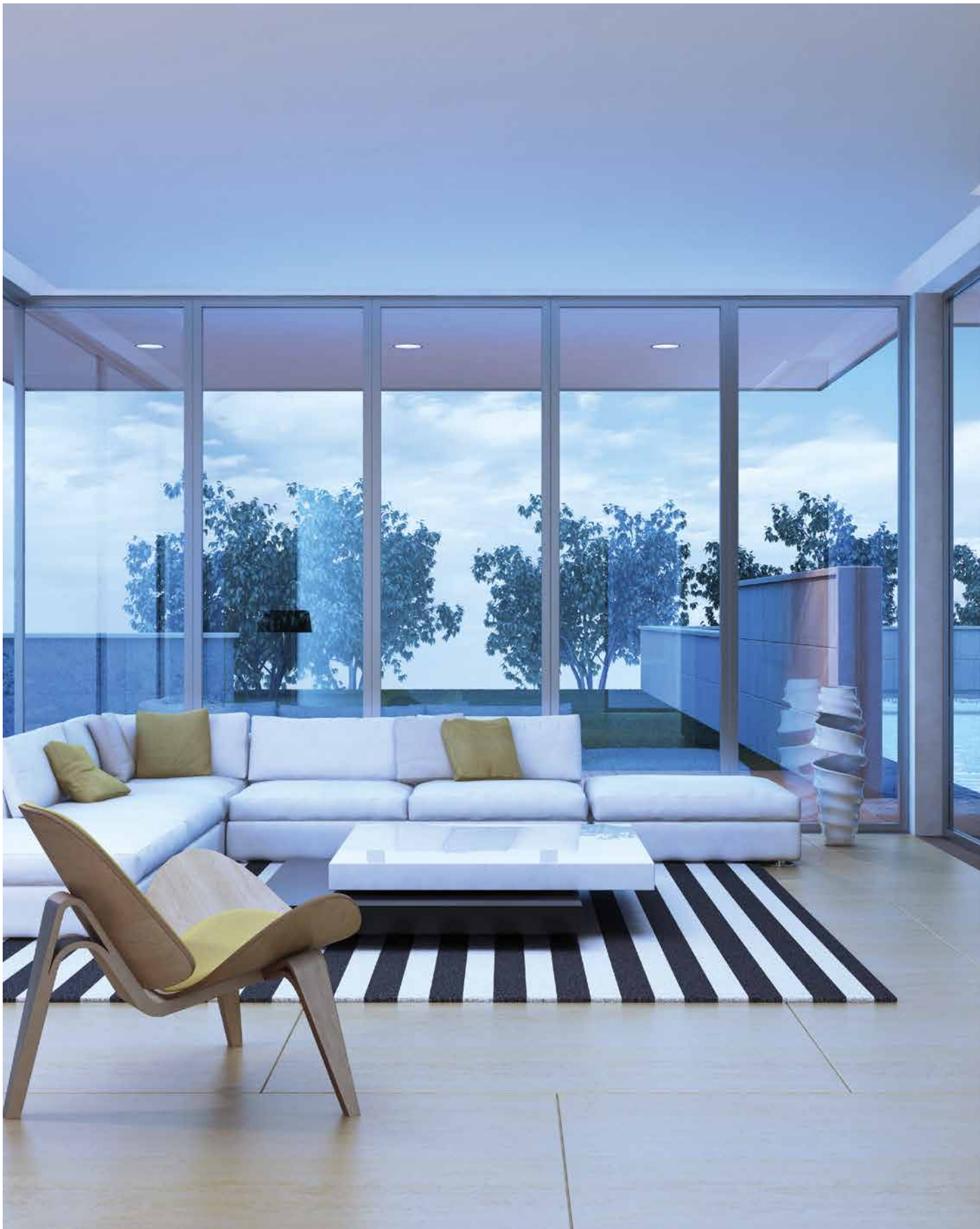

KLIMA NEW BUILDING

INTRODUCTION

KLIMA NEW BUILDING is the radiant floor system designed for new constructions or installations with no specific thickness requirement.

Panels are available smooth or with protrusions to satisfy every need, from residential to tertiary buildings. Models **R979G** and **R979TG** include protrusions designed to provide a convenient and quick clip-free pipe locking system. R981 are smooth insulation panels available in four different models to satisfy at best every project need. Every model features efficient soundproofing.





WHY CHOOSE IT?

- Ideal for new constructions and when there is no specific requirement for reduced installation thicknesses
- Wide range of insulation panels
- Certified and guaranteed products
- Excellent soundproofing

Find out more at giacomini.com

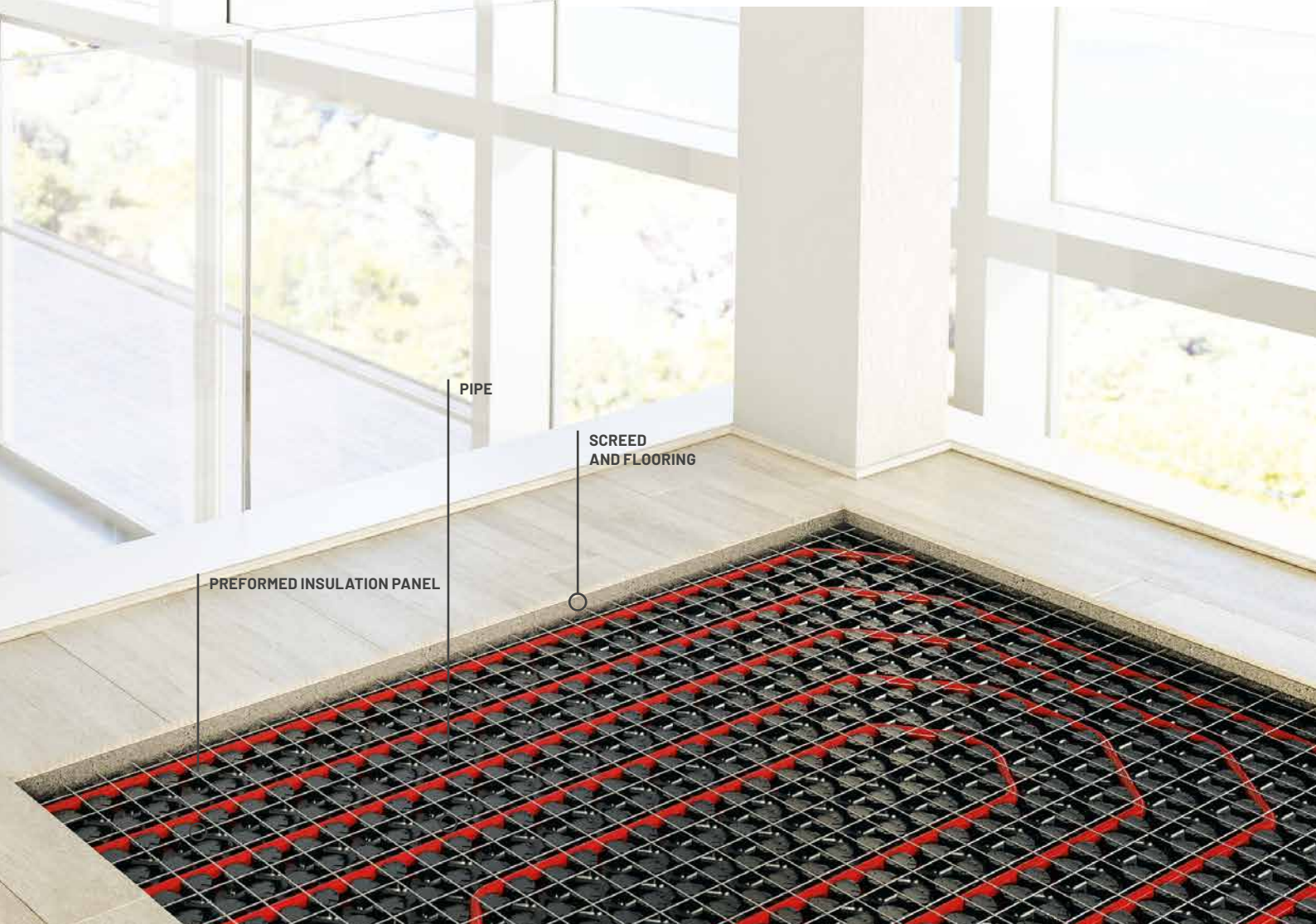

TYPES OF PANELS

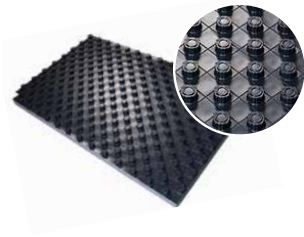
**R979G**

- Preformed EPS graphite-enhanced insulation panel
- Thicknesses: 32 mm/42 mm/52 mm/62 mm/75 mm
- Panel pitch: multiples of 50 mm

**R979TG**

- Preformed EPS graphite-enhanced insulation panel
- Thicknesses: 30 mm/50 mm/63 mm
- Panel pitch: multiples of 50 mm (also diagonal)

**R981B**

- EPS smooth insulation panel R981B
- Thicknesses: 30 mm/40 mm/50 mm/60 mm
- Panel pitch: multiples of 50 mm

**R981G**

- EPS graphite-enhanced insulation panel + smooth ESP-T
- Thicknesses: 30 mm/40 mm/50 mm/60 mm
- Panel pitch: multiples of 50 mm

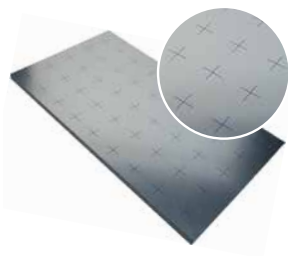
**R981AG**

- Preformed EPS graphite-enhanced insulation panel + smooth aluminum sheet
- Thicknesses: 25 mm/40 mm
- Panel pitch: multiples of 50 mm

**R981XPS**

- Smooth insulation panel XPS300/XPS500
- Thicknesses: 30 mm/40 mm/50 mm/60 mm
- Panel pitch: multiples of 50 mm

PANEL RAPID-SELECTION TABLE

Panel code	Smooth	With protrusions	Reduced thickness	Insulation	Insulation height (mm)	Panel total height (mm)	Thermal resistance	
R979BY113		•		EPS	10	32	0,29	page 25
R979BY114		•		EPS	20	42	0,57	page 25
R979BY115		•		EPS	30	52	0,86	page 25
R979BY116		•		EPS	40	62	1,14	page 25
R979BY117		•		EPS	53	75	1,51	page 25
R979TGY003		•		GRAPHITE-ENHANCED EPS	11	30	0,34	page 26
R979TGY005		•		GRAPHITE-ENHANCED EPS	31	50	0,97	page 26
R979TGY006		•		GRAPHITE-ENHANCED EPS	44	63	1,38	page 26
R979GY003		•		GRAPHITE-ENHANCED EPS	10	32	0,32	page 24
R979GY004		•		GRAPHITE-ENHANCED EPS	20	42	0,65	page 24
R979GY094		•		GRAPHITE-ENHANCED EPS	23	45	0,75	page 24
R979GY005		•		GRAPHITE-ENHANCED EPS	30	52	0,97	page 24
R979GY006		•		GRAPHITE-ENHANCED EPS	40	62	1,29	page 24
R979GY007		•		GRAPHITE-ENHANCED EPS	53	75	1,71	page 24
R981BY003	•			EPS	30	30	0,91	page 27
R981BY004	•			EPS	40	40	1,21	page 27
R981BY005	•			EPS	50	50	1,52	page 27
R981BY006	•			EPS	60	60	1,82	page 27
R981AGY003	•			GRAPHITE-ENHANCED EPS	25	25	0,81	page 28
R981AGY004	•			GRAPHITE-ENHANCED EPS	40	40	1,29	page 28
R981XY002	•			XPS300	20	20	0,59	page 29
R981XY003	•			XPS300	30	30	0,85	page 29
R981XY004	•			XPS300	40	40	1,15	page 29
R981XY005	•			XPS300	50	50	1,45	page 29
R981XY006	•			XPS300	60	60	1,75	page 29
R981XY015	•			XPS500	50	50	1,45	page 29
R981XY016	•			XPS500	60	60	1,75	page 29
R979SY101			•	-	-	22	-	page 36
R979SY011			•	-	-	22+13(pin)	-	page 36
R979SY021			•	EPS	0,6	28	0,19	page 36
R979SY005			•	-	-	15	-	page 37
R979SY025			•	EPS	0,6	21	0,19	page 37
R979SAY023			•	EPS-T WITH GRAPHITE	30	52	1	page 38
R979SAY025			•	EPS-T WITH GRAPHITE	50	72	1,67	page 38
R979SCY021			•	ESP CAM	10	32	0,3	page 39
R979SCY022			•	ESP CAM	20	42	0,61	page 39
R979SCY023			•	ESP CAM	30	52	0,91	page 39
R979SCY024			•	ESP CAM	40	62	1,21	page 39
R979SCY025			•	ESP CAM	50	72	1,52	page 39
R883Y101			•	EPS	28	28	0,65	page 44
R884Y101			•	EPS	28	28	0,65	page 44



KLIMA NEW BUILDING WITH R979G

R979G preformed insulation panels are the natural evolution of the R979 panel: they feature the same geometric characteristics but with enhanced insulation capacity thanks to their EPS graphite-enhanced polystyrene insulation. The panels include a dual-density graphite-enhanced polystyrene sheet (EPS) combined to a 0,6 mm-thick surface protection layer in preformed

polystyrene. They cut down manpower thanks to their special protrusions, with preformed fins that hold the pipes firmly in place without clips. Fit for circuits with 50 mm-multiple pitches and pipes with a 16-18 mm external diameter.

The R979G range is one of the widest available on the market for its thicknesses and thermal resistance values.

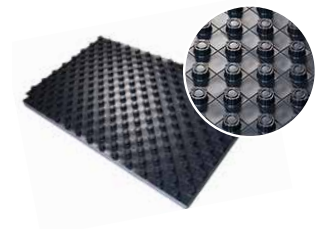

👍 WHY CHOOSE IT?

- EPS graphite-enhanced for efficient thermal insulation
- Ideal for new constructions and when there is no specific requirement for reduced installation thicknesses
- Wide range of thicknesses
- Certified and guaranteed products

TECHNICAL DATA	R979GY003	R979GY004	R979GY094	R979GY005	R979GY006	R979GY007
(A) Panel total height - mm	32	42	45	52	62	75
Insulation/protrusion height - mm	10/22	20/22	23/22	30/22	40/22	53/22
(B) Screed min. height - mm	30	30	30	30	30	30
(C) a+b total height without coating - mm	62	72	75	82	92	105
Panel dimensions	1450x850	1450x850	1450x850	1450x850	1450x850	1450x850
Panel surface	1,23	1,23	1,23	1,23	1,23	1,23
Thermal conductivity	0,030	0,030	0,030	0,030	0,030	0,030
Thermal resistance	0,78	1,10	0,75	1,42	1,74	2,16
Compression resistance	>=200	>=150	>=150	>=150	>=150	>=150



Section with the R979G panel

KLIMA NEW BUILDING WITH R979B

The special configuration of the preformed protrusion enables to firmly grip pipes with a 16-17 mm external diameter. Preformed insulation panels R979B save time when laying the pipes and can be used to create circuits with multiples of 50 mm. The available thicknesses, with total heights ranging between 32 mm and 75 mm, enable to install radiant floor heating and cooling systems in any type of work site, even with limited space, such

as renovation projects. All panels R979B feature a very simple and efficient connection system. The surface coating is 50 mm larger than the insulation sheet underneath on both sides. The two larger edges overlapping the contiguous panels connect to each other, creating a homogeneous support base for the radiant circuits with no heat bridges, which are typical of panels lacking a solid connection system.

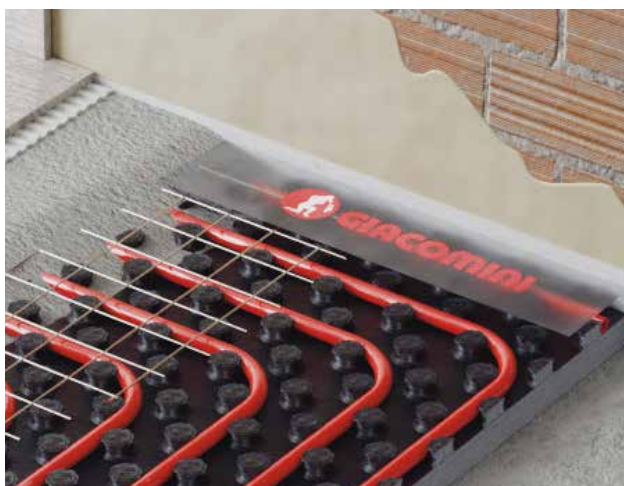

👍 WHY CHOOSE IT?

- EPS graphite-enhanced for efficient thermal insulation
- Ideal for new constructions and when there is no specific requirement for reduced installation thicknesses
- Certified and guaranteed products

TECHNICAL DATA	R979BY103 R979BY113	R979BY104 R979BY114	R979BY105 R979BY115	R979BY106 R979BY116	R979BY107 R979BY117
(A) Panel total height - mm	32	42	52	62	75
Insulation/protrusion height - mm	10/22	20/22	30/22	40/22	53/22
(B) Screed min. height - mm	30	30	30	30	30
(C) a+b total height without coating - mm	62	72	82	92	105
Panel dimensions	1400x800	1400x800	1400x800	1400x800	1400x800
Panel surface	1,23	1,23	1,23	1,23	1,23
Thermal conductivity	0,035	0,035	0,035	0,035	0,035
Thermal resistance	0,70	0,99	0,86	1,14	1,51
Compression resistance	150	150	150	150	150



Section with the R979G panel

KLIMA NEW BUILDING WITH R979TG

The R979TG preformed insulation panels are the natural evolution of the R979N panel: they feature the same geometric characteristics but with enhanced insulation capacity thanks to their EPS graphite-enhanced polystyrene insulation. The panels include a graphite-enhanced polystyrene sheet (EPS), with dual density in the two thicker sizes, able to enhance soundproofing and combined to a 0,6 mm-thick surface protection



layer in preformed polystyrene. They cut down manpower thanks to their special protrusions, with preformed fins that hold the pipes firmly in place without clips. Fit for circuits with 50 mm-multiple pitches and pipes with a 16-17 mm external diameter. The R979TG panel is also fit for diagonal installation of the pipes with a 70-mm pitch, a solution highly in demand for modern residential units with customized geometries.

👍 WHY CHOOSE IT?

- EPS graphite-enhanced insulation and dual density
- EPS graphite-enhanced for efficient thermal and acoustic insulation
- Ideal for new constructions and when there is no specific requirement for reduced installation thicknesses
- Wide range of thicknesses
- Certified and guaranteed products



TECHNICAL DATA	R979TGY003	R979TGY005	R979TGY006
A Panel total height - mm	30	50	63
Insulation/protrusion height - mm	11/19	31/19	44/19
B Screed min. height - mm	30	30	30
C a+b total height without coating - mm	60	80	93
Panel dimensions	1450x850	1450x850	1450x850
Panel surface	1,23	1,23	1,23
Thermal conductivity	0,031	0,031	0,031
Thermal resistance	0,49	1,10	1,40
Density	30	30-13	30-13
Compression resistance	>=250	>=100	>=100

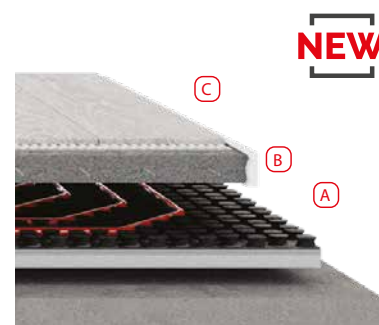

Section with R979TG panel

KLIMA NEW BUILDING WITH R981B

Smooth insulation the R981B panels consist of an expanded polystyrene sheet (EPS) including a surface layer with a grid for simplified pipe laying. Fit for a variety of applications in both residential or tertiary buildings, these panels are especially recommended for large surfaces (churches,

industrial warehouses, etc.). The panels are smooth with tapping for coupling and the radiant coils can be fitted on top using pipe installation tracks (K389 or K389W) or the R983 special clips (with R863 clip tacker).

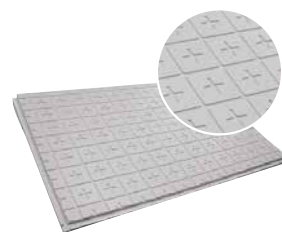

👍 WHY CHOOSE IT?

- EPS insulation
- Ideal for new constructions and when there is no specific requirement for reduced installation thicknesses
- Wide range of thicknesses
- Certified and guaranteed products

TECHNICAL DATA	R981BY003	R981BY004	R981BY005	R981BY006
(A) Panel total height - mm	30	40	50	60
(B) Screed min. height - mm	30*	30*	30*	30*
(C) a+b total height without coating - mm	60+pipe d.	70+pipe d.	80+pipe d.	90+pipe d.
Panel dimensions	1200x800	1200x800	1200x800	1200x800
Panel surface	0,96	0,96	0,96	0,96
Thermal conductivity	0,033	0,033	0,033	0,033
Thermal resistance	0,91	1,21	1,52	1,82
Density	Class E	Class E	Class E	Class E
Compression resistance	>=200	>=200	>=200	>=200

* Starting from the pipe top

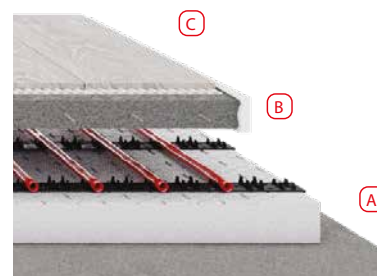

Section with R981B panel

KLIMA NEW BUILDING WITH R981AG

Insulation the R981A panels are the top of the smooth panel range and fit for refined and high-performance applications. The panels include a dual-density graphite expanded polystyrene sheet, graphite-enhanced EPS, combined to a 0,25 mm-thick aluminum protection layer with grid for simplified pipe laying. The aluminum sheet distributes the heat evenly and rapidly along the entire floor surface. They are fit for a

variety of residential and tertiary applications. The smooth panels feature an aluminum adhesive side extending outwards for rapid coupling to the adjacent one and firm laying. The panels are smooth with tapping for coupling and the radiant coils can be fitted on top using pipe installation tracks (K389 or K389W) or the R983 special clips (with R863 clip tacker).

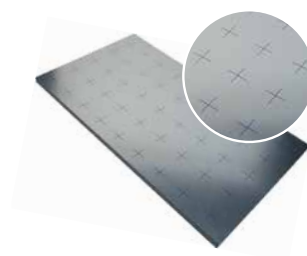

👍 WHY CHOOSE IT?

- EPS graphite-enhanced insulation
- 0,25 mm-thick aluminum sheet
- Ideal for new constructions and when there is no specific requirement for reduced installation thicknesses
- Certified and guaranteed products

TECHNICAL DATA	R981AGY003	R981AGY004
(A) Panel total height - mm	25	40
Aluminum - mm	0,25	0,25
(B) Screed min. height - mm	30*	30*
(C) a+b total height without coating - mm	55+pipe d.	70+pipe d.
Panel dimensions	1000x500	1000x500
Panel surface	0,5	0,5
Thermal conductivity	0,031	0,031
Thermal resistance	0,81	1,29
Density	Class E	Class E
Compression resistance	>=200	>=200

* Starting from the pipe top

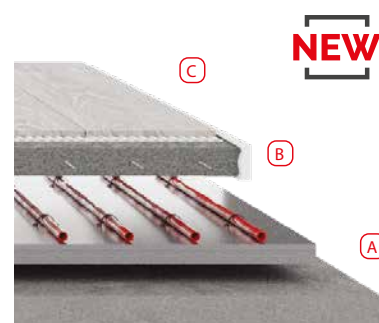

Section with R981AG panel

KLIMA NEW BUILDING WITH R981XPS

Smooth insulation the R981XPS panels consist of an extruded polystyrene foam sheet (XPS). Fit for a variety of applications in both residential and tertiary buildings, these panels are especially recommended for large surfaces (churches, industrial warehouses, etc.) or when a high compression resistance is required. Available in

XPS300 and XPS500. The panels are provided smooth with shiplap edge for rapid and firm coupling and the radiant coils can be fitted using pipe installation tracks (K389 or K389W) or the R983 special clips (with R863 clip tacker) after covering the panel surface with the R984 polyethylene protection sheet.



👍 WHY CHOOSE IT?

- XPS insulation
- Ideal for new constructions and when there is no specific requirement for reduced installation thicknesses
- Wide range of thicknesses
- Certified and guaranteed products

DATI TECNICI	R981XY002	R981XY003	R981XY004	R981XY005	R981XY006	R981XY015	R981XY016
A Panel total height - mm	20	30	40	50	60	50	60
B Screed min. height - mm	30*	30*	30*	30*	30*	30*	30*
C a+b total height without coating - mm	50	60+pipe d.	70+pipe d	80+pipe d	90+pipe d	80+pipe d	90+pipe d
Panel dimensions	1250x600	1250x600	1250x600	1250x600	1250x600	1250x600	1250x600
Panel surface	0,75	0,75	0,75	0,75	0,75	0,75	0,75
Thermal conductivity	0,034	0,034	0,034	0,034	0,034	0,034	0,034
Thermal resistance	0,59	0,85	1,15	1,45	1,75	1,45	1,75
Density	Class E	Class E	Class E	Class E	Class E	Class E	Class E
Classification	XPS300	XPS300	XPS300	XPS300	XPS300	XPS500	XPS500

* Starting from the pipe top

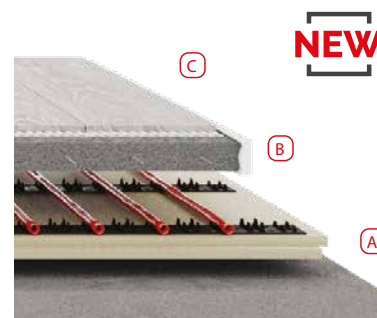

Section with R981XPS panel

MATCHING PRODUCTS

PIPE

p. 64-67



MANIFOLD

p. 52-57

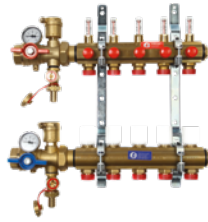

KLIMADOMOTIC

p. 86



ACCESSORIES

p. 114-122



ELECTROWELDED MESH

p. 119

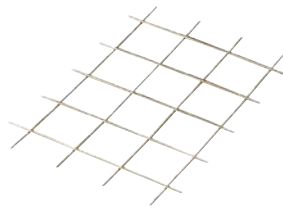

CABINET

p. 59



THERMOREGULATION

p. 75-82



AIR TREATMENT

p. 107-111



Refer to chapter Installation

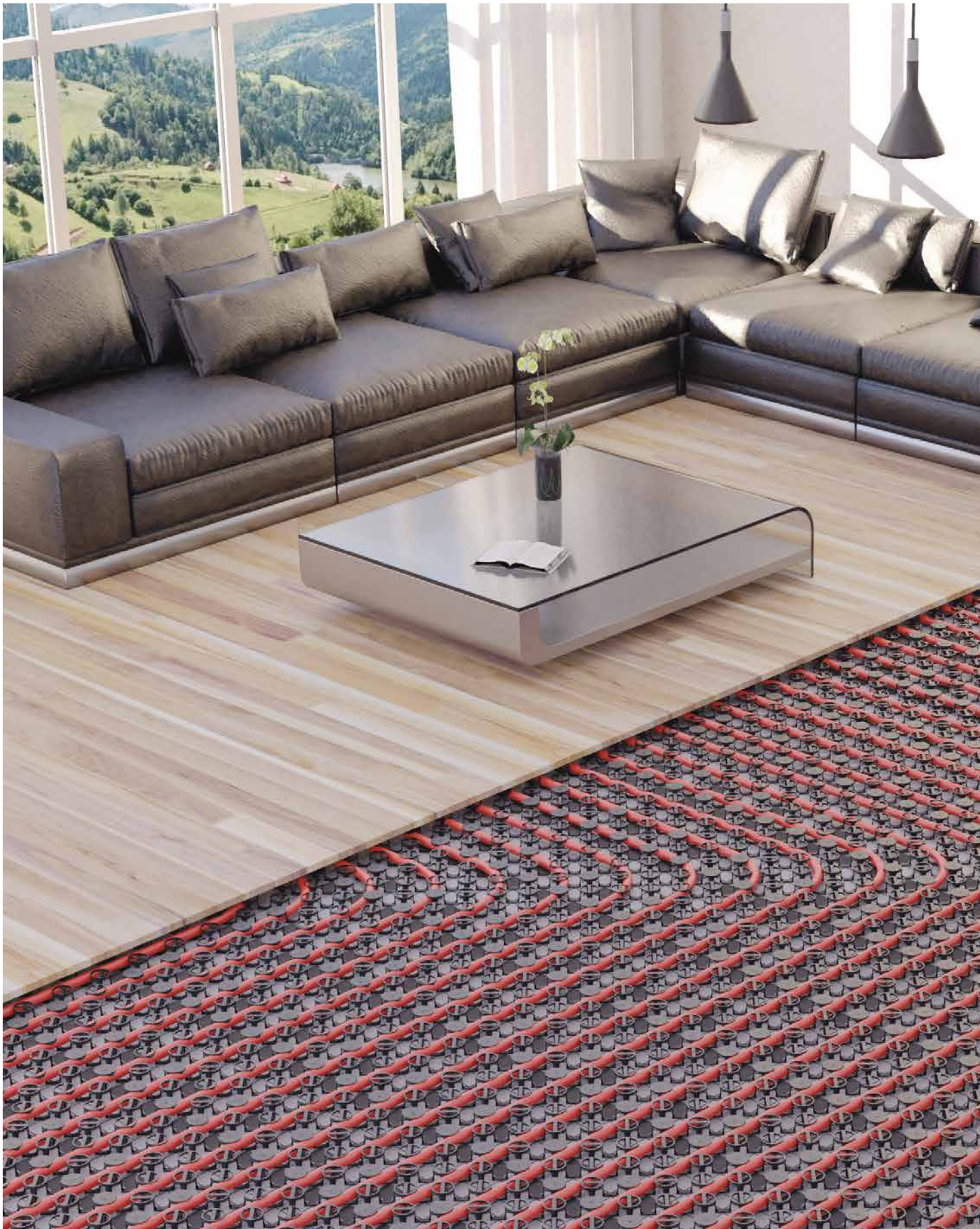

KLIMA RENEW

INTRODUCTION

KLIMA RENEW is the system designed to meet the growing demand for radiant floors even in those situations where the thickness available for installation is very reduced: the perfect **solution for renovation works**.

It can be realized with the **Spider** and **Spider SLIM** special plastic panels (series R979S), on which \varnothing 16-17 mm pipes are installed for the standard version while \varnothing 12 pipes are used for the SLIM version. As an alternative, we also provide fiber-plaster panels with \varnothing 12 mm polybutylene pipes coated with a self-leveling screed.

All KLIMA RENEW systems guarantee extremely reduced thermal inertia to rapidly reach the operational regime after attenuation or deactivation of the radiant floor.





WHY CHOOSE IT?

- The ideal solution for new constructions and when there is no specific requirement for reduced installation thicknesses
- Reduced thickness
- Reduced thermal inertia
- Panels with high mechanical resistance
- Rg79S is fit for use with standard-diameter pipes (16 to 17 mm)

Find out more at giacomini.com

PREFORMED PLASTIC PANEL

SELF-LEVELING SCREED

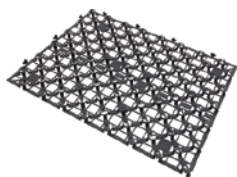

TYPES OF PANELS

**R979S WITH ADHESIVE BASE**

- Thicknesses: 22 mm
- Panel pitch: multiples of 50 mm
- Suitable pipes: Ø 16-17 mm

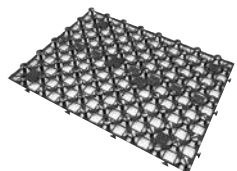
**R979S WITH FITTING PINS**

- Thicknesses: 22 mm
- Panel pitch: multiples of 50 mm
- Suitable pipes: Ø 16-17 mm

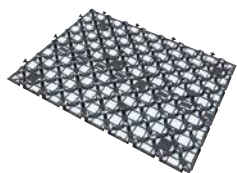
**R979S WITH HIGH-DENSITY INSULATION**

- Thicknesses: 28 mm (22 mm + 6 mm insulation)
- Panel pitch: multiples of 50 mm
- Suitable pipes: Ø 16-17 mm

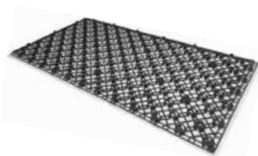
**R979S SLIM WITH ADHESIVE BASE**

- Thickness: 15 mm
- Panel pitch: multiples of 50 mm
- Suitable pipes: Ø 12 mm

**R979SLIM WITH HIGH-DENSITY INSULATION**

- 21 mm thickness (15 mm + 6 mm insulation)
- Panel pitch: multiples of 50 mm
- Suitable pipes: Ø 12 mm

**R979SA ACOUSTIC**

- Thickness: 30 and 50 mm
- Panel pitch: 5 cm
- Suitable pipes: Ø 16+17 mm

**R979SC CAM-CERTIFICATION**

- Thickness: 10-50 mm
- Panel pitch: 5 cm
- Suitable pipe: Ø 16+17 mm

PANEL RAPID-SELECTION TABLE

Panel code	Smooth	With protrusions	Reduced thickness	Insulation	Insulation height (mm)	Panel total height (mm)	Thermal resistance	
R979SY101			•	-	-	22	-	page 36
R979SY011			•	-	-	22+13 (pin)	-	page 36
R979SY021			•	EPS	0,6	28	0,19	page 36
R979SY005			•	-	-	15	-	page 37
R979SY025			•	EPS	0,6	21	0,19	page 37

www.giacomini.com

Your freedom to renovate begins where Spider Slim ends.



Spider Slim, the system for thin and light radiant floors.

Spider Slim is an innovative system with top-notch performance that lowers the screed and offers unlimited renovation freedom. The result of Giacomini's research, this preformed panel with bidimensional geometry is a compact solution to achieve the best uniformity in thermal energy distribution.

Spider Slim has a 50 mm laying pitch and can be used with self-levelling compounds, reducing the screed height up to 2 cm. A carefree choice for your renovation needs.





Available with adhesive layer of insulation in height ranges between 15-20 mm.



GIACOMINI
WATER E-MOTION



KLIMA RENEW WITH SPIDER STANDARD PANELS

R979S Spider and Spider Slim panels form a "3D" grid molded in plastic, more precisely in high-resistance polypropylene. Their limited height and shape make them particularly fit for renovation works with a consequent energy efficiency upgrade. The patented geometry of the 3D grid enables to firmly fit the pipe during laying while drowning it completely in the screed. This provides an even and flawless heat distribution along with limited thermal inertia. Available are five versions: R979SY001 and R979SY005 with adhesive base for gluing on existing floor or foundation; R979SY011 with fitting pins for installation on existing insulation

layer; R979SY021 and R979SY025 combined to a 6-mm high-density insulation layer. The screed thickness can be calculated starting from the base of the panel as the concrete mixture can easily penetrate the tridimensional grid. Suitable for self-leveling screeds (with R979SY001-005 and R979SY021-025 panels only) anhydrite-based screeds and traditional sand-concrete screeds (for all three versions). Giacomini provides the minimum geometric limits to comply with, yet inviting users to strictly comply with the thicknesses and installation techniques specified by the manufacturer's technical datasheets.



👍 WHY CHOOSE IT?

- The ideal solution for renovation works and when low installation thicknesses are required
- Reduced thickness
- 16-18 mm pipe
- Reduced thermal inertia

TECHNICAL DATA	R979SY101	R979SY011	R979SY021
A Panel total height - mm	22	22 + pins	28 (6 mm insulation included)
Insulation/protrusion height - mm	-	S _i *	6
B Screed min. height - mm	25 (with self-leveling screed) 35 (with anhydrite-based screed) 40 (with sand + concrete screed)	35 (with anhydrite-based screed) 40 (with sand + concrete screed)	30 (con autolivellante) 35 (con anidritico) 40 (con sabbia + cemento)
C a+b min. height without coating - mm	25 (with self-leveling screed) 35 (with anhydrite-based screed) 40 (with sand + concrete screed)	35 + S (with anhydrite-based screed) 40 + Si (with sand + concrete)	36 (with self-leveling screed) 41 (with anhydrite-based screed) 46 (with sand + concrete screed)
Panel dimensions	1200x800	800x600	800x600
Panel surface	0,48	0,48	0,48
Thermal conductivity	-	-	0,032
Thermal resistance	-	-	0,19
Density	-	-	-
Compression resistance	-	-	>=200

S_i* not Included with Spider

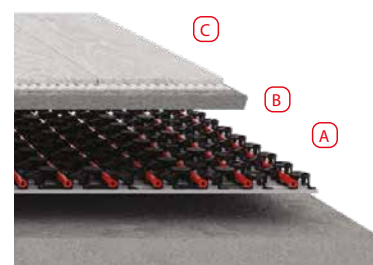

Section with Spider panel

KLIMA RENEW WITH SPIDER SLIM PANELS

R979S Spider Slim panels form a "3D" grid molded in plastic, more precisely in high-resistance polypropylene. Their limited height and shape make them particularly fit for renovation works with a consequent energy efficiency upgrade. The patented geometry of the 3D grid enables to firmly fit the pipe during laying while drowning it

completely in the screed.

This provides an even and flawless heat distribution along with limited thermal inertia. They are available in two versions: R979SY005, with adhesive base to glue it on existing floors or foundations; R979SY025, combined to a 6 mm-thick high-density insulation layer.



👍 WHY CHOOSE IT?

- The ideal solution for renovation works and when low installation thicknesses are required
- Very low thickness (lower than standard version)
- 12 mm pipe
- Reduced thermal inertia

TECHNICAL DATA	R979SY005	R979SY025
(A) Panel total height - mm	15	21
Insulation/protrusion height - mm	-	6
(B) Screed min. height - mm	20 (with self-leveling screed) 35 (with anhydrite-based screed) 40 (with sand + concrete screed)	20 (with self-leveling screed) 35 (with anhydrite-based screed) 40 (with sand + concrete screed)
(C) a+b min. height without coating - mm	20 (with self-leveling screed) 35 (with anhydrite-based screed) 40 (with sand + concrete screed)	26 (with self-leveling screed) 41 (with anhydrite-based screed) 46 (with sand + concrete screed)
Panel dimensions	1200x600	1200x600
Panel surface	0,72	0,72
Thermal conductivity	-	0,032
Thermal resistance	-	0.19
Density	-	-
Compression resistance	-	>=200

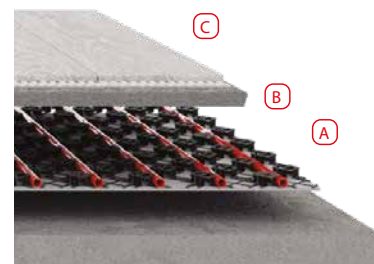

Section with Spider panel

KLIMA RENEW WITH R979SA

The R979SA Spider panel is a “three-dimensional” grid molded in plastic, or more precisely, in high-resistance polypropylene combined to an EPS elasticized panel with graphite. It features reduced dynamic stiffness which offers enhanced soundproofing in proper screed heights (Min. height 60 mm above insulation). The range includes a

variety of accessories, such as the soundproofing edge strip, to complete this dedicated technical solution. The patented geometry of the three-dimensional grid enables to firmly fit the pipe during laying while drowning it completely into the screed. This provides an even and flawless heat distribution along with enhanced soundproofing.



👍 WHY CHOOSE IT?

- EPS elasticized insulation panel with graphite providing enhanced soundproofing
- Enhanced thermal insulation
- 17x2 - 16x2 pipe

TECHNICAL DATA	R979SAY023	R979SAY025
Panel total height - mm	52	72
(A) Insulation/protrusion height - mm	30/22	50/22
(B) Screed min. height - mm	60	60
(C) a+b min. height without coating - mm	90	110
Panel dimensions	1200x800	1200x800

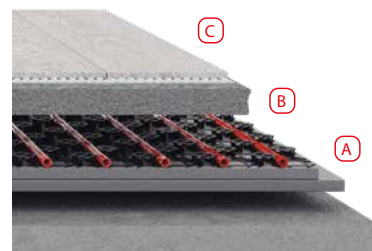

Section with R979SA panel

KLIMA RENEW WITH R979SC

The R979SC Spider panel is a "three-dimensional" grid molded in plastic, or more precisely, in high-resistance polypropylene combined to a CAM-certified (minimum environment criteria) EPS panel, and therefore fit for installation in public premises. This panel range includes a variety of heights, from 10 mm up to 50 mm. . The patented

geometry of the three-dimensional grid enables to firmly fit the pipe during laying while drowning it completely into the screed. the pipe compared to traditional systems.

This provides an even and flawless heat distribution and reduce the screed height on top of the pipe compared to traditional systems.



👍 WHY CHOOSE IT?

- CAM-certified insulation panel
- Lower screeds compared to traditional radiant floor systems
- 16x2 - 17x2 pipe

TECHNICAL DATA	R979SCY021	R979SCY022	R979SCY023	R979SCY024	R979SCY025
Panel total height - mm	32	42	52	62	72
(A) Insulation/protrusion height - mm	10/22	20/22	30/22	40/22	50/22
(B) Screed min. height - mm	40 (with sand + concrete screed)	40 (with sand + concrete screed)	40 (with sand + concrete screed)	40 (with sand + concrete screed)	40 (with sand + concrete screed)
(C) a+b min. height without coating - mm	50	60	70	80	90
Panel dimensions	1200x800	1200x800	1200x800	1200x800	1200x800
Resistenza compressione	>=200	>=150	>=150	>=150	>=150

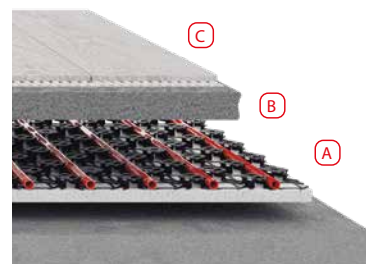

Section with R979SC panel

KLIMA RENEW WITH R883F / R884F

The R883F panels are made by a fiber-plaster sheet specifically milled to house the 12x1,5 mm polybutylene pipe, thus enabling to create distribution circuits with a 10 cm pitch.

The reduced-thickness system, together with the R883F main component, is combined to the R884F head and submanifold panels: these enable to

connect the pipes to the manifold and the various circuits and to neatly install the pipes near the manifold itself. The system requires a self-leveling screed of about 5 mm on top of the panel surface to obtain a very reduced overall thickness of the radiant floor. The system complies with certified green-building applications.



Giacomini can provide installation datasheets by the major screed manufacturers when using self-leveling screeds.

TECHNICAL DATA	R979SY001
(A) Panel total height - mm	18
(B) Screed min. height - mm	5
(C) a+b min. height without coating - mm	23
Panel dimensions	1200x600
Panel surface	0,72
Conduttività termica	0,32
Thermal conductivity	-
Density	1159
Compression resistance	>=150

MATCHING PRODUCTS

PIPE

p. 64-67



MANIFOLD

p. 52-57

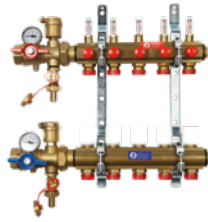

KLIMADOMOTIC

p. 86



ACCESSORIES

p. 114-122



CABINET

p. 59



THERMOREGULATION

p. 75-82



AIR TREATMENT

p. 107-111



Refer to Installation chapter

KLIMA DRY

INTRODUCTION

KLIMA DRY is the **screed-free** radiant floor system perfect for interventions where the weight on structures must be limited (e.g. renovation works or galleries): this major requirement is satisfied by not using a concrete screed to support the surface finish while reducing installation times and thicknesses. It uses R883-1 panels which are made by a preformed polystyrene foam sheet combined to an aluminum diffuser layer to enhance heat exchange between the pipes (preferably multilayer) and the surface. These panels include a special fitting system to prevent thermal bridging.

The layer supporting the surface finish provides for dry laying of a double layer of galvanized steel sheets which guarantees an even distribution of the mechanical loads.

TYPES OF PANELS

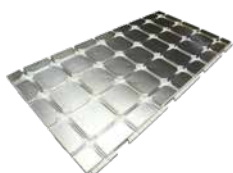

R883-1 WITH ALUMINUM HEAT-TRANSFER PROFILE

- Thicknesses: 28 mm
- Panel pitch: multiples of 150 mm
- Suitable pipes: Ø 16-17 mm



R884 HEAD PANEL

- Thicknesses: 28 mm
- Panel pitch: multiples of 150 mm
- Suitable pipes: Ø 16-17 mm





WHY CHOOSE IT?

- No concrete screed required
- Reduced thickness and light
- The ideal solution for new constructions and when there is no specific requirement for reduced installation thicknesses
- Reduced thermal inertia
- Use of pipes with 16-17 mm external diameter

Find out more at giacomini.com

POLYETHYLENE SHEET

STEEL SHEETS

PANEL + PIPE

R883-1 / R884

The R883-1 preformed insulation panels are made with polystyrene foam fitted to a heat-transfer profile consisting of a 0,3 mm-thick aluminum sheet.

The four sides of the panel feature special joints for simplified connection to the adjacent ones and elimination of thermal bridging. R884 head panels, made with polystyrene foam with a thermoformed

aluminized film, enable to properly fit circuit abduction pipes and support bends. The layer supporting the surface finish, for distribution of the mechanical loads, consists of a double layer of galvanized steel sheets: R805P for the first layer, R805P-1 with double-sided adhesive for the second. The layers must be properly staggered to seal the gaps between the sheets.



TECHNICAL DATA	R883-1	R884
(A) Panel total height - mm	28	28
(B) Distribution layer height - mm	2 (1+1)	2 (1+1)
(C) a+b total height without coating - mm	30	30
Panel dimensions	1200x600	600x300
Panel surface	0,72	0,18
Thermal conductivity	0,034	0,034
Thermal resistance	0,55	0,034
Density	30	30
Compression resistance	200	200

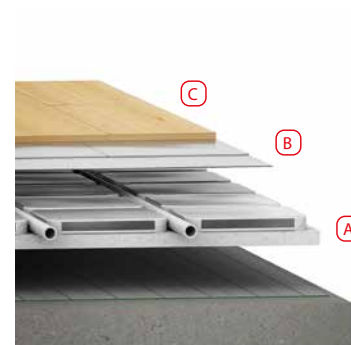

Section with R881XPS panel

MATCHING PRODUCTS

PIPE

p. 64-67



MANIFOLD

p. 52-57

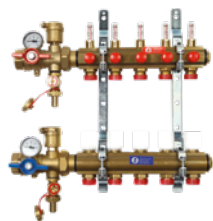

KLIMADOMOTIC

p. 86



ACCESSORIES

p. 114-122



CABINET

p. 59



THERMOREGULATION

p. 75-82



AIR TREATMENT

p. 107-111



GALVANIZED STEEL SHEET



INSTALLATION STEPS



1. Laying of wall edging strip



2. Laying of steam barrier polyethylene sheet



3. Laying of R884 head insulation panel



4. Laying of R883-1 insulation panel with coupled aluminum heat transfer profile

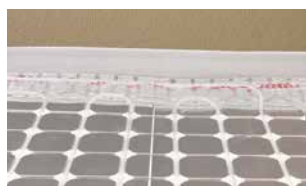

5. Pipe installation



6. Positioning of first galvanized steel sheet layer



7. Positioning of second galvanized steel sheet layer properly staggered



8. Laying of surface finish (floating on special mat recommended)

KLIMA WALL

INTRODUCTION

KLIMA WALL is our radiant wall system. It represents the ideal solution when other radiant systems cannot be installed or when heat **integration is required**.

Radiant wall circuits can be connected directly to the distribution manifolds of the floor system.

The Klima Wall radiant system is installed using K389W tracks, available as 1-m bars easy to connect and providing the required support to the circuits. Wall mounting on the rough surface and fitting the pipes in place is quick and easy.

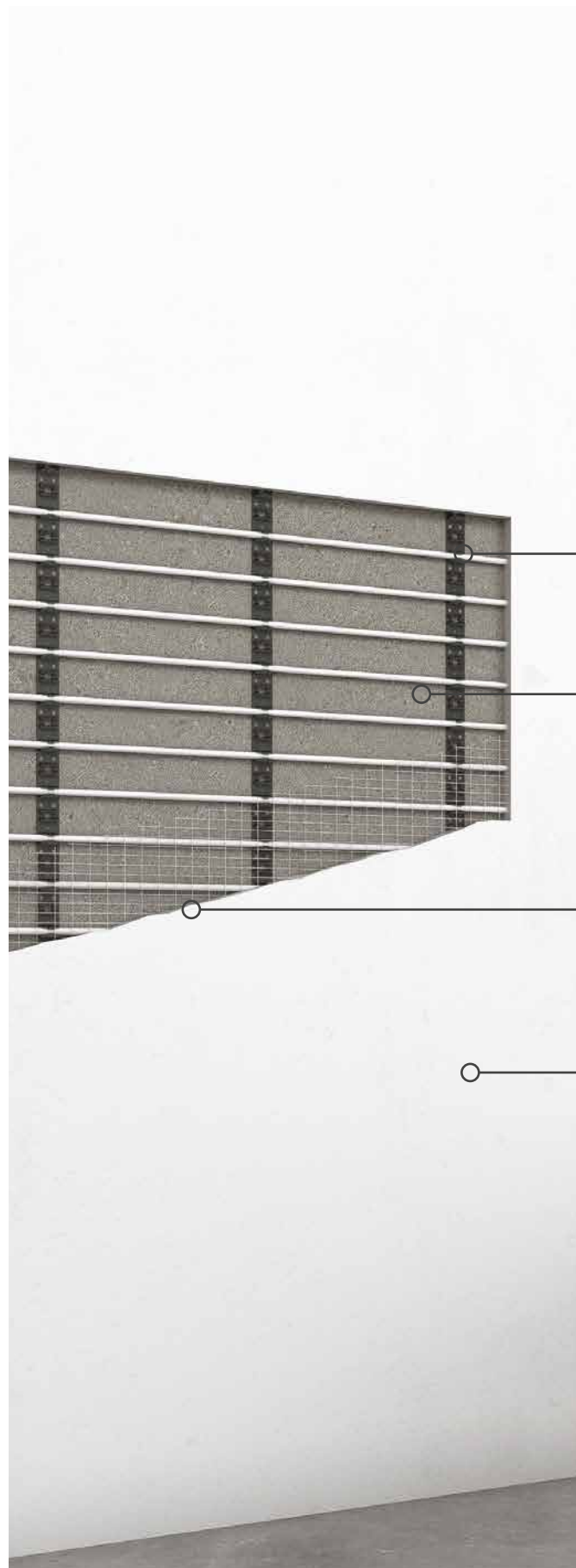

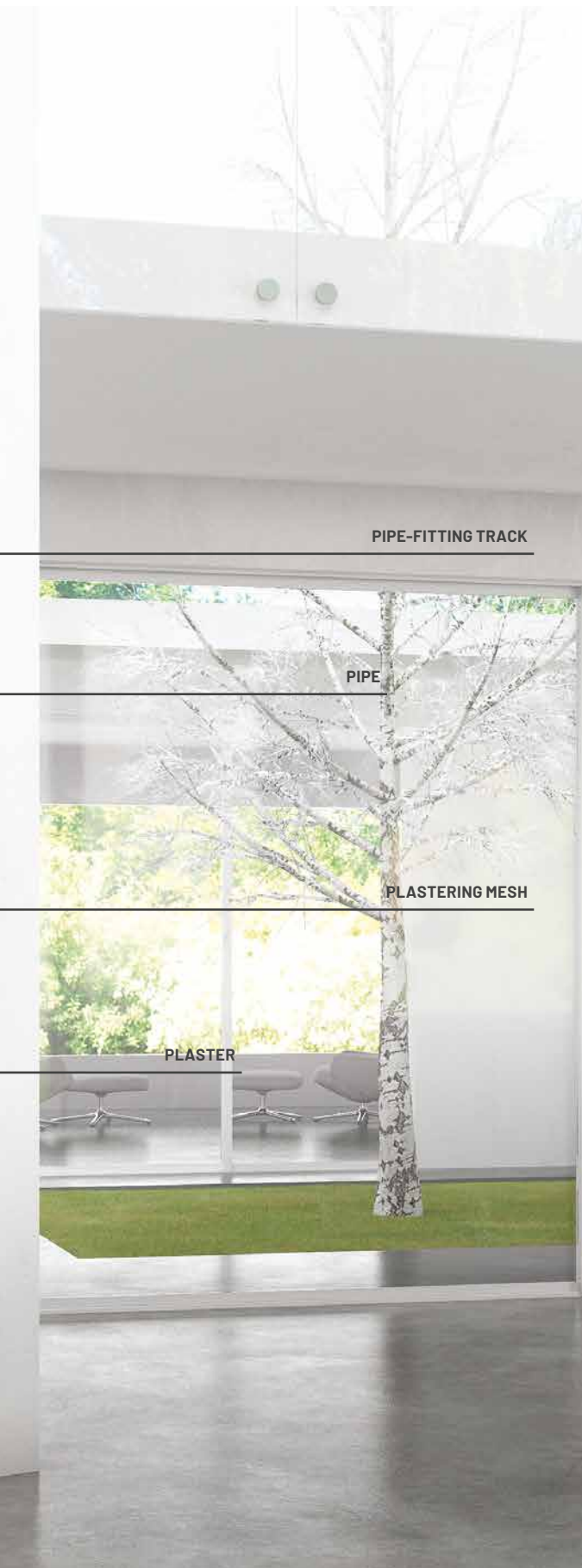

👍 WHY CHOOSE IT?

- The ideal solution when other radiant systems cannot be installed
- Even distribution of heat
- Reduced thermal inertia
- Easy to install
- Use of pipes with 16-17 mm external diameter

Find out more at giacomini.com

KLIMA WALL

Radiant wall systems are generally – but not exclusively – dedicated to units where the exploitable floor surface is not sufficient to install a radiant system (e.g. stairwells, bathrooms), that is rooms where the specific thermal need is relatively higher than the rest of the domestic environment.

The best way to reduce to the minimum the wall surface dedicated to the radiant system and enhance the thermal yield while minimizing thermal expansion is to lay the pipes with a 10 cm pitch; this, in addition to the reduced thickness of the piping plaster, enables to enjoy thermal yields not lower than those developed by the radiant floor as the wall system can exploit the same distribution manifold¹.

The Klima Wall radiant system is installed using

K38gW tracks, available as 1-m bars easy to connect and providing the required support to the circuits. The tracks must be fitted vertically to the wall using the provided screw and plug holes. The distance between two adjoining tracks must not exceed 50 cm, while the circuits connected to the manifold must be laid preferably at a 2-2,5 m maximum height from the ground. Pipes can be quickly and neatly fitted in the track housings. A mortar-based plastering with plaster and concrete binders is recommended as coating layer for the KLIMA WALL radiant system. The plaster layer must be reinforced with a plastering mesh. The thickness of the coating covering the system must be at least 10 mm. To prevent dispersions, we recommend installing the system on an surface with an external insulation.

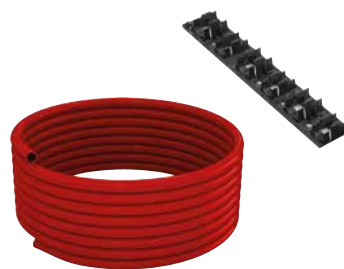

TECHNICAL DATA	KLIMA WALL		
A B + C minimum thickness beyond the wall - mm	~ 40		
B Track + pipe - mm	28		
C Plaster min. thickness - mm	10		
Pipe diameter - mm	12 - 15	16 - 18	20
Pitch - mm	multiples of 100	multiples of 50	multiples of 100

Considering a bathroom at 21 °C and with a 40 °C delivery temperature, the output would be approx. 100 W/m².
 Note: the average heating temperature of radiant walls must not exceed 40 °C (according to UNI EN 1264-3) and when the pipes are drowned in plaster-based plaster, the delivery temperature must not exceed 50 °C (according to UNI EN 1264-4).

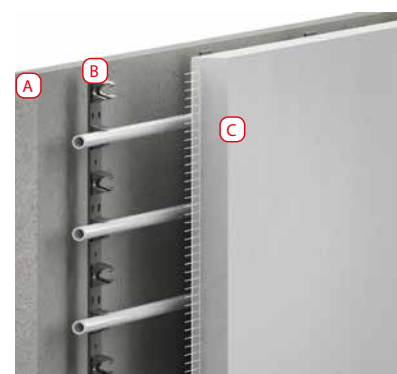

A Brick wall
 B Pipe-fitting track
 C Mortar-based plaster with plastering mesh

MATCHING PRODUCTS

PIPE

p. 64-67



MANIFOLD

p. 52-57

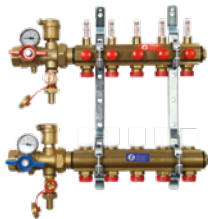

KLIMADOMOTIC

p. 86



ACCESSORIES

p. 114-122



CABINET

p. 59



THERMOREGULATION

p. 75-82



AIR TREATMENT

p. 107-111





MIXING AND DISTRIBUTION MANIFOLDS

Complete range. User-friendly installations. Reduced installation times. A manifold range designed to meet every installation requirement. From basic distribution terminals up to preassembled units integrating water mixing and distribution.

Brass or plastic, the hydraulic solution for every radiant circuit.





R559N

The R559N manifold is used for **heating and cooling control** of combined systems, that is those with high-temperature (heated towel rails or radiators) and low-temperature (fan coils and dehumidifiers for cooling integration) heating elements as well as radiant panel circuits fed with properly mixed water.

The distribution manifolds of the preassembled unit include 4-12 outputs for mixed water circuits while the non-mixed water circuits (direct outputs)

are sold separately. The optional metering kit (1" delivery and return with filter, zone valve and metering unit spacer) can be used with centralized systems. The self-modulating circulator complies with the ErP 2009/125/CE energy-saving directive. The Klimabus thermoregulation system by Giacomini controls the temperature electronically through the K281 motor. The unit is provided with shut-off valves, drain cocks, air vent valves and delivery and return thermometers.

FLOW DIAGRAM

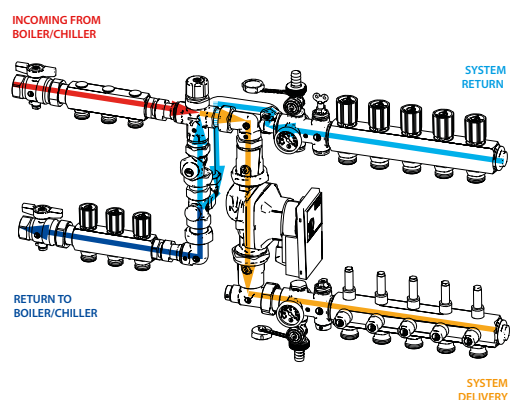

CONNECTION EXAMPLE

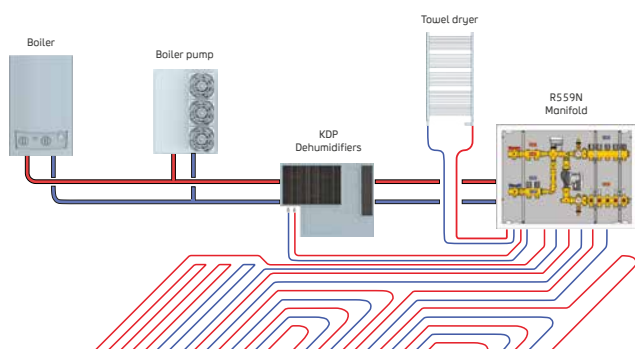

👍 WHY CHOOSING IT?

- Suitable also for cooling
- Preassembled
- Easy to install
- Equipped with self-modulating circulator
- Possibility to add manifolds for non-mixed water circuits
- Compact cabinet

R557R-2

The R557R-2 manifold is a fixed-point regulation mixing unit. It is generally used for distribution in radiant floor circuits for **heating only**.

Temperature control of the delivery water to the radiant system is provided through a 3-way valve equipped with a temperature-limiter thermostatic head. Sold separately are special kits to supply mixed water-systems: in other words, high-temperature heating units (towel heated rails or radiators) are combined to radiant panel circuits

working on low-temperature water. The range also includes an optional metering kit (1" delivery and return with filter, zone valve and metering unit spacer) for use with centralized heating systems. The unit is provided assembled and wired in its cabinet for quick and easy installation. It includes a variable flow-rate circulator, complying with the ErP 2009/125/CE energy saving-directive, and the K373 safety thermostat.

FLOW DIAGRAM

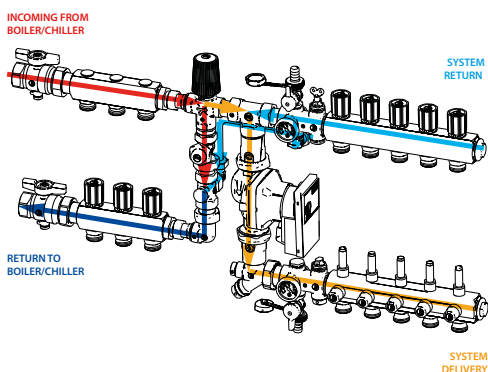

CONNECTION EXAMPLE

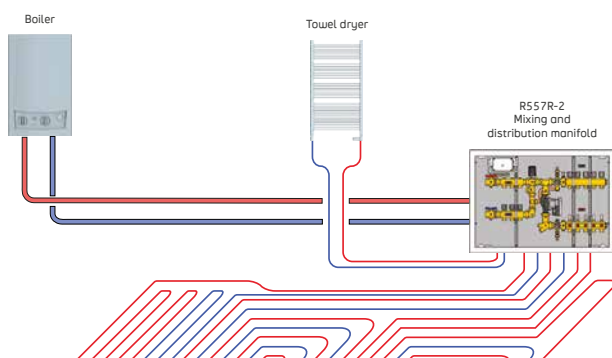

👍 WHY CHOOSING IT?

- Preassembled
- Easy to install
- Equipped with self-modulating circulator
- Possibility to add manifolds for non-mixed water circuits
- Compact cabinet



MANIFOLDS

Distribution manifolds of radiant panel systems play a key role: they hydraulically supply every single circuit with the flow rate required for proper operation. Different systems have different needs: that is why Giacomini has designed a full range

to cover every type of installation. From basic distribution manifolds to pre-assembled units integrating water mixing and distribution. In brass, plastic and stainless steel. The best hydraulic solution for every type of radiant system.

R553FK / R553DK

PREASSEMBLED BRASS MANIFOLD

The best solution for water distribution in radiant air conditioning systems. The unit, pre-assembled on brackets or fixing clamps, consists of a delivery manifold, provided with balancing lockshields and flow rate meters (R553FK only) as well as a return

manifold with shut-off valves where the thermo-electric actuators can be installed. Included are also the R26gT multifunction valves to shut-off the water flow, display the temperature, fill/empty the system or vent the air from inside.

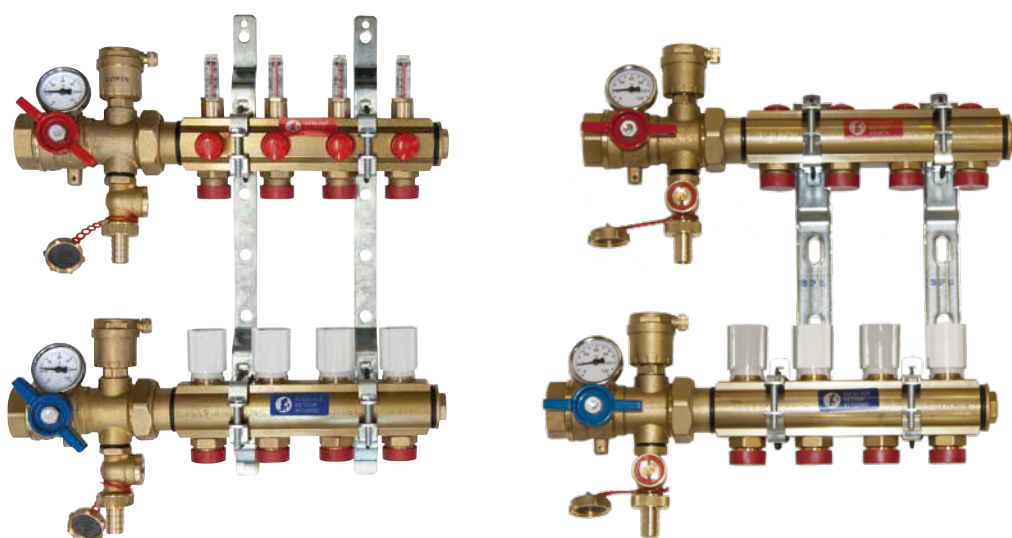

R553FP

PREASSEMBLED TECHNOPOLYMER MANIFOLD

Modular brass manifold for water distribution in radiant air conditioning systems. The manifold can be assembled on-site with the 2 to 4 modules included. Assembly is quick and effective thanks to its synchronized threading which ensures sealing and state-of-the-art coupling of the single modules. The range includes manifold modules with regulation lockshields, valves with thermostatic option and flow meters. Also provided are ball valves with thermometer, terminal units with air vent and drain cocks as well as brackets for quick anchoring to the cabinet. Available with separate components or as ready-to-assemble KIT.



R553FS

PREASSEMBLED STAINLESS STEEL MANIFOLD

Technopolymer cooling manifold featuring plastic construction materials with enhanced insulation characteristics for insulation-free systems. The unit consists of a delivery manifold, provided with balancing lockshields and flow rate meters, and a return manifold with shut-off valves where the thermo-electric actuators can be installed.

Its modular design enables to add or remove the modules (outlets). The special o-ring provides hydraulic seal between the modules while mechanical fitting is obtained through the special plastic clips. This model includes R26gT multifunction valves as well.

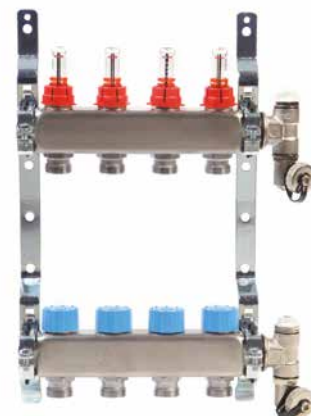

SERIE DB

PREASSEMBLED MANIFOLDS WITH INTEGRATED DYNAMIC BALANCING

All basic distribution manifolds by Giacomini are equipped with the innovative DB bonnet by Giacomini, for accurate and independent flow rate control in every circuit of the system.

- Pre-assembled units for heating and cooling systems with automatic flow rate control.
- Available in a range of materials to meet the market demand: brass, technopolymer,

NEW



R553FKDB



R553FPDB

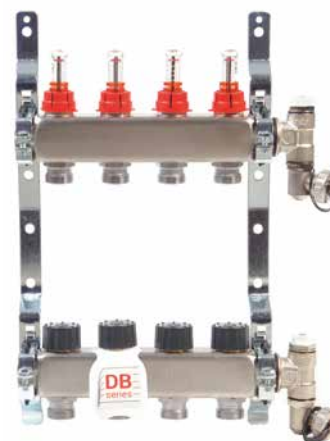

R553FSDB



- stainless steel
- Return manifold with inserts with thermostatic option and continuous (dynamic) regulation of the flow rate inside every circuit
- Delivery manifold with flow meters to set the

- circuit maximum flow rate and shut-off function
- Based on the version, they are provided with intermediate or terminal fittings for a variety of functions (shut-off, temperature display, drain cock, air venting)

MAIN BENEFITS

Full and accurate control: preregulation, continuous regulation and shutting off

Balanced flow rate in every circuit for top levels of comfort and energy saving

Upgrading interchangeability: **same dimensions and center distances** of the manifolds

Quick and easy circuit calibration, especially in complex installations to be upgraded

FLOW-RATE PREREGULATION CHART

No thermostatic head

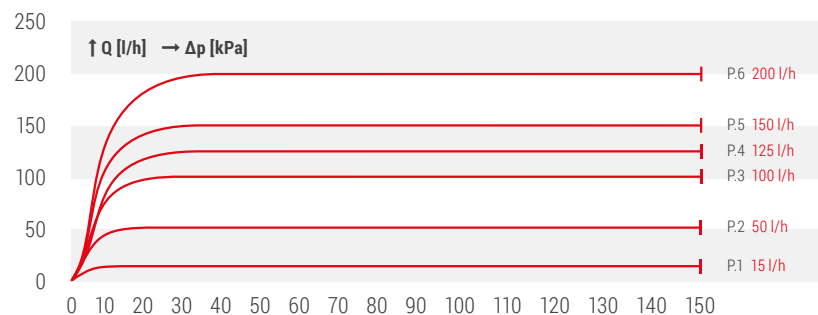

MANIFOLD ACCESSORIES

MULTIFUNCTION VALVES R269T

Designed for installation upstream of the distribution manifolds, they integrate the following functions:

- shut-off ball valve with red and blue lever
- automatic air-vent device equipped with self-sealing shut-off valve
- drain cock
- contact thermometer
- inlet for temperature immersion probe

They can be easily installed at the manifold inlet in a reversible way with fluid adduction from left or right.



BALL VALVE R259D

To ensure shutting-off of delivery and return manifold flows:

- female-male tail pieces
- red or blue T handle
- temperature range: - 20÷185 °C
- max. working pressure at 20 °C with water: 42 bar (3/4") and 35 bar (for larger dimensions)



R554D MANIFOLD INTERMEDIATE FITTING

The ideal accessory for basic distribution manifolds:

- automatic air vent
- drain cock
- 0÷80 °C thermometer
- self-sealing joint



R179/R179AM/R179E ADAPTORS

For connection of circuit piping to manifolds:

- for plastic or multilayer pipes
- for hydraulic systems, with black o-ring complying with EN681-1
- temperature range: 5÷110 °C
- max. working pressure: 10 bar



R500-2 FLUSH-MOUNTING METAL CABINET FOR MANIFOLDS

For state-of-the-art wall-mount installation of distribution manifolds:

- adjustable depth and height
- metal mesh for plastering
- modularity for installation on site
- packing with extremely reduced thickness



R553W INSULATION SET

To prevent manifold dispersions and localized moisture in cooling systems

- for bar and/or modular manifolds
- for ball valves R259D and/or multifunction valves R269T
- for intermediate fittings R554D4D



R500-2E FLUSH-MOUNTING METAL CABINET FOR MANIFOLDS

For state-of-the-art flush mounting of distribution manifold:

- flush to the wall
- adjustable depth and height
- 80-mm min depth
- modularity for installation on site
- packing with extremely reduced thickness





RADIANT SYSTEM PIPES

User-friendly installation and safety guaranteed in time to ensure our systems always perform at best.

PLASTIC PIPES

The pipes through which the heat transfer fluid flows play a key role in radiant floor systems.

From a strictly physical-technical standpoint, the best choice is to use highly conductive materials generally used in civil heating systems - e.g. copper or steel - as they are involved in the thermal exchange for transmission of radiant power to the environment. In modern radiant systems instead, plastic pipes are more in demand as they feature a smaller thermal conductivity coefficient in favor of more advantageous functions.

What are the benefits deriving from the chemical-physical properties of plastic pipes?

- Highly reliable on the long term, that is mechanical resistance to temperature and

pressure stress

- No corrosions typical of metals (the pipes are drowned in the flooring which prevents such phenomenon)
- Great versatility of installation. The flexible pipes enable to conveniently create spiral and coil radiant circuits
- Low cost, as the production capacity of modern installations is constantly growing

The radiant system pipe range by Giacomini includes:

- PEX cross-linked polyethylene
- PE-RT polyethylene of raised temperature
- PB polybutylene
- PEX/Al/PEX Multilayer



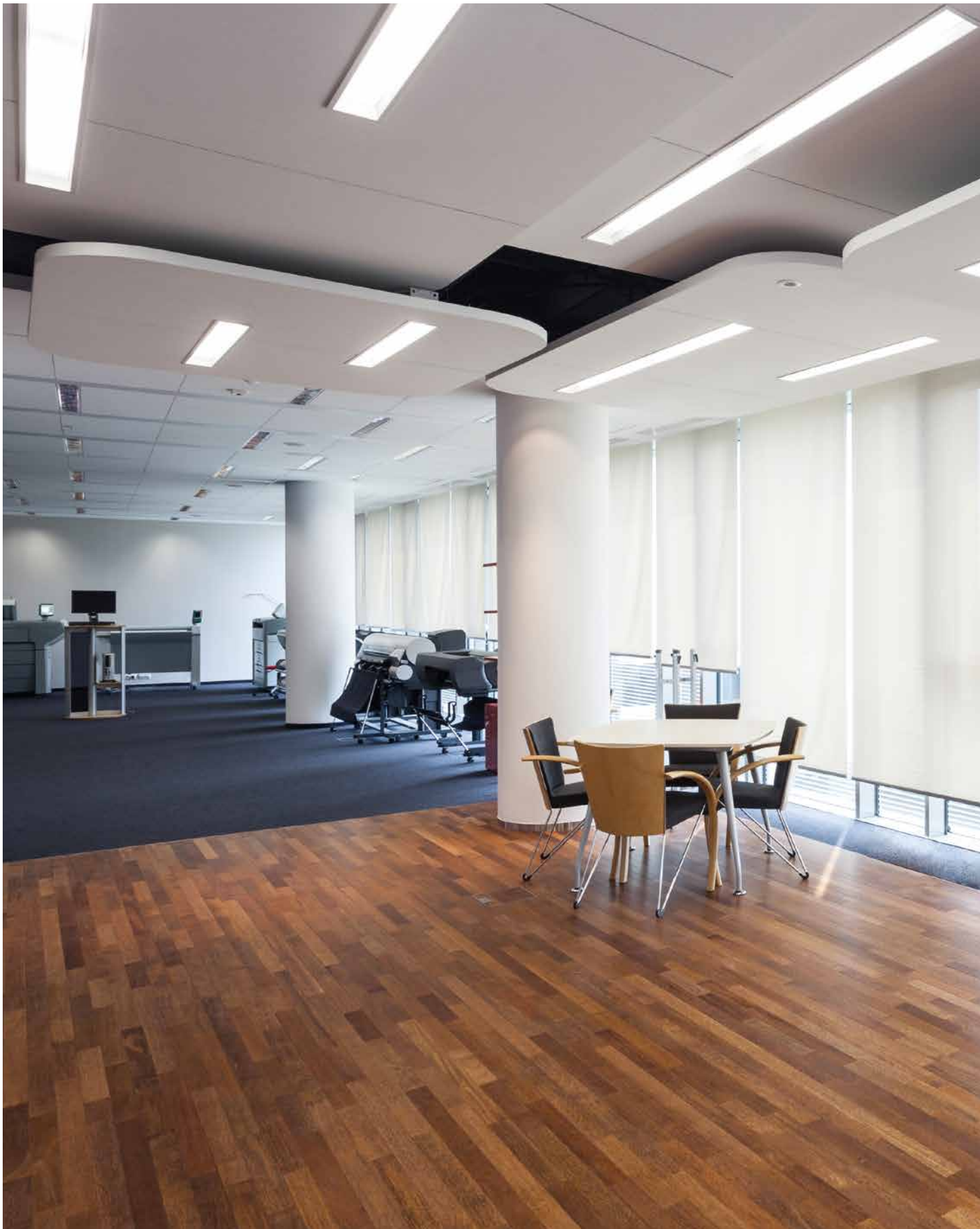

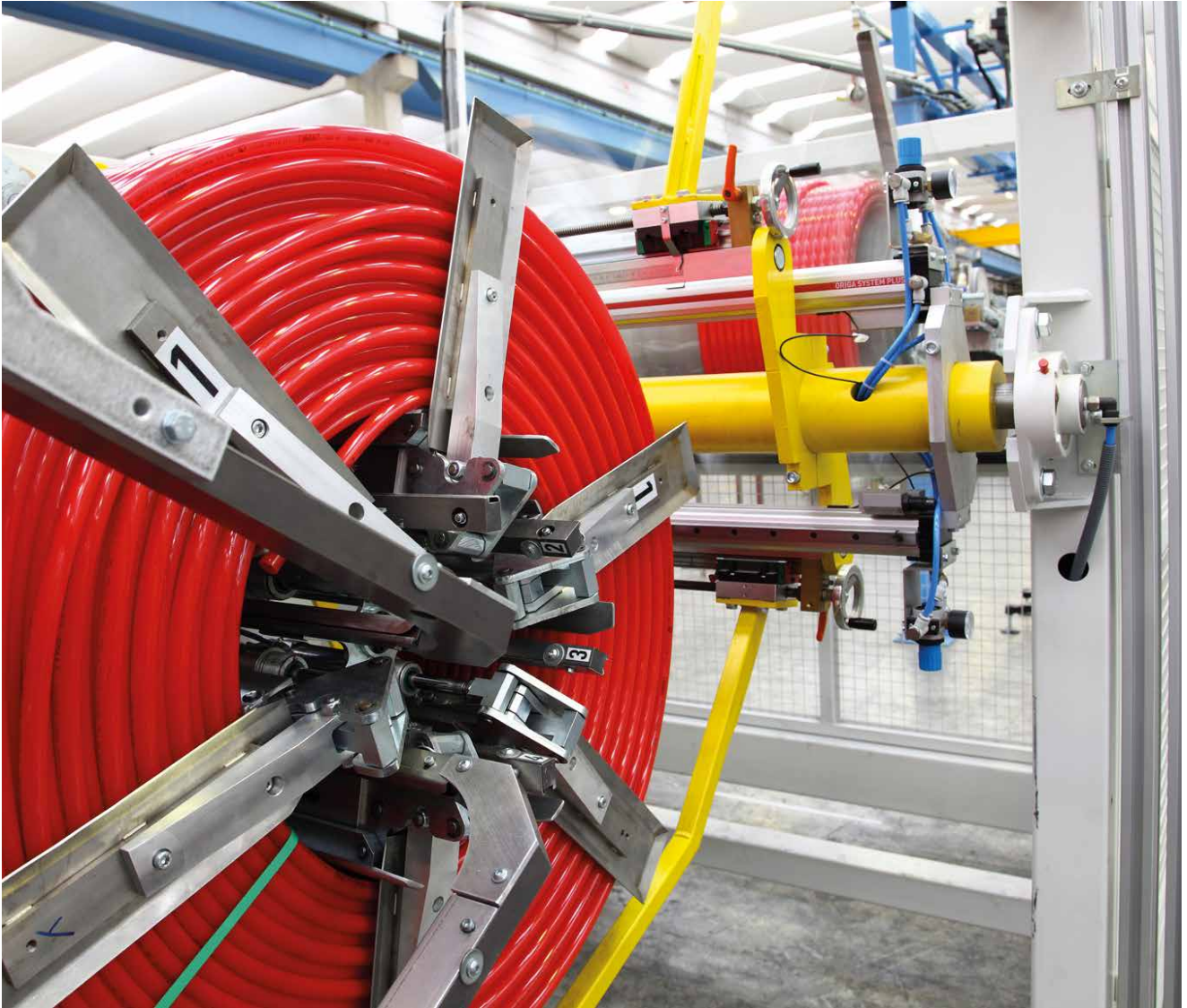

Giacomini's in-house production relies on new generation extruders to manufacture the pipes in line up to coiling starting from the pellet base polymer. The pictures below show some steps of the extrusion production process. Every phase is carried out in compliance with the

rules in force and technically tested according to regulatory standards. The plastic pipes for hot and cold water transfer are made according to the EN-ISO 15875 standard of reference which classifies the different types in "Classes of Application". (see table fig. 4.1).

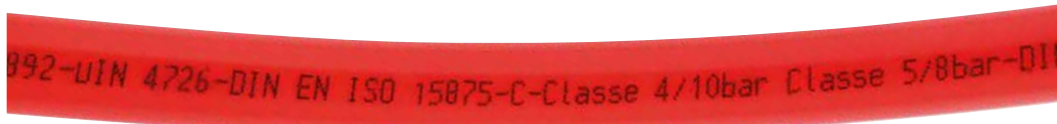

4.1

FIELD OF APPLICATION	CLASS (MARKED ON THE PIPE WITH ITS MAX. WORKING PRESSURE)	ICON OF REFERENCE
Domestic hot water (60 °C)	1	
Domestic hot water (70 °C)	2	
Floor heating and low-temperature radiators	4	
High-temperature heating radiators	5	

Giacomini manufactures Class 4 pipes for radiant applications which are meant to last 50 years at a constant working pressure of 4 bar

according to the conditions defined by the "regression curve" shown in fig. 4.2."

4.2

CLASS OF APPLICATION	TYPICAL FIELD OF APPLICATION	PROJECT TEMPERATURE T_D - °C	WORKING LIFE (YEARS) AT T_D TEMPERATURE	T_{MAX} - °C	WORKING LIFE (YEARS) AT T_{MAX} TEMPERATURE - °C	T_{MAL} - °C	WORKING LIFE (YEARS) AT T_{MAX} TEMPERATURE - °C
4	floor heating and low-temperature radiators	20	2,5	70	2,5	100	100
		followed by					
		40	20				
		followed by					
		60	25				
followed by - next column		followed by - next column					
5	high-temperature radiators	20	14	90	1	100	100
		followed by					
		60	25				
		followed by					
		80	10				
followed by - next column		followed by - next column					

With reference to class 4 applications, the temperature profile provides for 20 °C for 2,5 years, followed by 40 °C for 20 years, 60 °C for 25 years, 70 °C for 2,5 years and 100 °C for 100 hours.
 T_D - °C is the water temperature (or set of temperatures) for which the system has been planned
 T_{max} - °C is the highest project temperature achievable only for short times
 T_{mal} - °C is the highest project temperature achievable when the control systems fail



So far we have described the benefits offered by plastic pipes in radiant floor applications. Yet, there is also a potential issue: **oxygen permeability**. Oxygen may penetrate the circuits and the oxygen-enriched water may corrode the metal parts of the entire system (including the generator), favoring ferrous and micro algae deposits which

in time would lead to malfunctions and affect the overall output.

This can be prevented upon extrusion by applying **an EVOH resin film on the pipe (in an external or intermediate position) which works as barrier**. This makes the reduced quantity of oxygen seeping inside the pipe even more negligible.



R996T PEX PIPE

The PEX pipe is no doubt the most popular in radiant systems. The level of molecule cohesion of the base polymer used to produce it, **PE polyethylene**, does not guarantee an ideal performance in terms of resistance and duration: that is why **the cross-linking process**, which increases the number of existing chemical-molecular bonds to enhance mechanical and high-tem-

perature resistance, is key.

There are two ways to achieve this reinforcement process: chemical and physical.

In the former, the cross-linking process takes place along with extrusion by means of chemical additives. In the latter, on the contrary, the manufactured pipe is bombarded with electron beams. There are different types of PEX based on the

cross-linking process used:

- **PEX-a:** chemical cross-linking by means of catalysts known as peroxides which cross link the pipe permanently upon extrusion
- **PEX-b:** chemical cross-linking by means of catalysts known as silanes. In this case however the cross-linking process is accelerated after extrusion by submerging the product in water at a controlled temperature or in steam
- **PEX-c:** physical cross-linking by electron bombarding.

Worth noting is that the quality of a pipe does not depend on the cross-linking method but on many other factors such as: base compound formulations, type of extrusion machines, accuracy of production quality assurance and subsequent inspections and lab tests on the end product.

In fact, the only standard of reference for the

production of PEX pipes (EN-ISO 15875) describes the physical and dimensional characteristics of the product along with the minimum cross-linking degree to guarantee an adequate resistance to temperature and pressure: for PEX-b, 65% is sufficient.

Giacomini produces in house all polyethylene pipes by cross-linking them through the silane chemical process.

R996T PEX-b pipes feature a very high thermal resistance combined to a very reduced elastic content of **enhanced flexibility**. This provides for quick and easy installation along with a major reduction of stresses, even after laying.

The R996T pipes are extruded with an external EVOH anti-oxygen barrier complying with EN ISO 15875 and DIN 4726 to prevent any permeability to oxygen.



👍 WHY CHOOSING IT?

- Enhanced flexibility
- Quick and easy installation

TECHINCAL DATA

R996T PEX PIPE

Range of application: class 4 and class 5 (EN ISO 15875)

Density - g/cm³: 0,939

Thermal conductivity - W/(m K): 0,38

Linear dilation coefficient - 1/K:

(1,9x10⁻⁴)

Breaking load - MPa: 31

Breaking extension point %: 520

Elasticity module 23 °C - MPa: 540

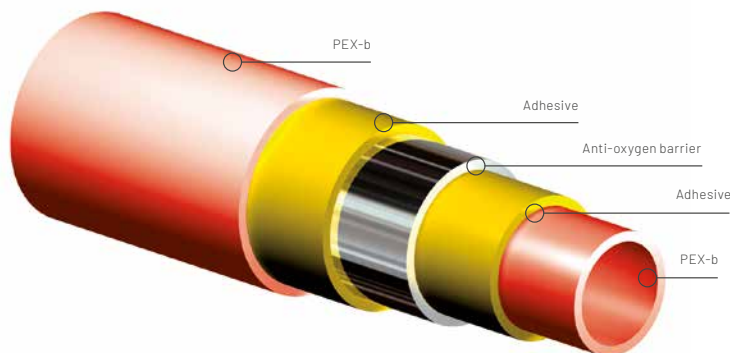

R978 PE-RT PIPE

R978 PE-RT pipes, made in **polyethylene with enhanced thermal resistance**, differ from cross-linked polyethylene PEX right from their raw material: the basic compound used for PE-RT is specific for this type of production. On a molecular level, it is a polyethylene polymeric chain containing a minimum percentage **of the 1-octene molecule** which provides an enhanced

temperature resistance compared to classic polyethylene (not cross-linked). In this way, the extruded pipe requires no additional molecular reinforcement.

The resistance to the pressure-temperature stress, typical of a PE-RT pipe, makes this product fit for mixed-water distribution in radiant panel systems.

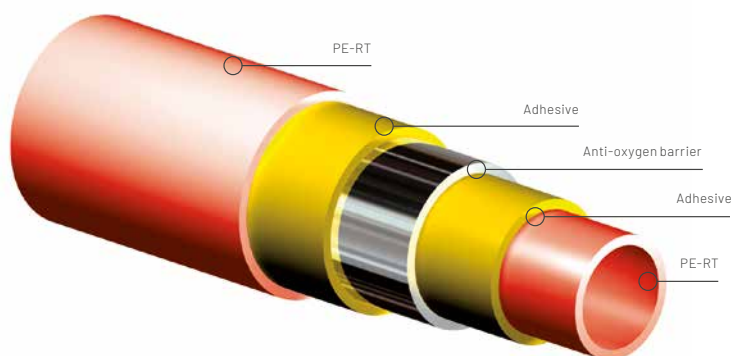

TECHINCAL DATA

R978 WITH ANTI-OXYGEN BARRIER, 5-LAYER PE-RT PIPES

Range of application - class 4 (ISO 22391)

Not fit for domestic water transfer

Density - 0,941 g/cm³

Thermal conductivity - 0,40 W/(m K)

Linear dilation coefficient - $(1,8 \times 10^{-4})/K$

Breaking load - 36 MPa

Breaking extension point - 760 %

Elasticity module - 650 MPa

R999 PEX-AL-PEX MULTILAYER PIPE

The **PEX /Al /PEX metal-plastic multilayer pipe** includes an inner and an outer layer of PEX-b and one intermediate layer of aluminum welded lengthwise with laser technology. The special intermediate glue layers evenly connect the aluminum layer to the inner and outer PEX-b. It combines the mechanical characteristics of metal pipes to enhanced resistance to wear and tear and potential electrochemical interactions

typical of plastic pipes. The intermediate aluminum layer **butt welded with laser technology** provides a safe barrier against oxygen and other gases, as well as great flexibility for bending with a reduced radius while maintaining the laying shape when installing the circuits. R999 PEX /Al/PEX multilayer pipes are widely used for cooling/heating systems – among which radiant floor and wall installations – and domestic water distribution.

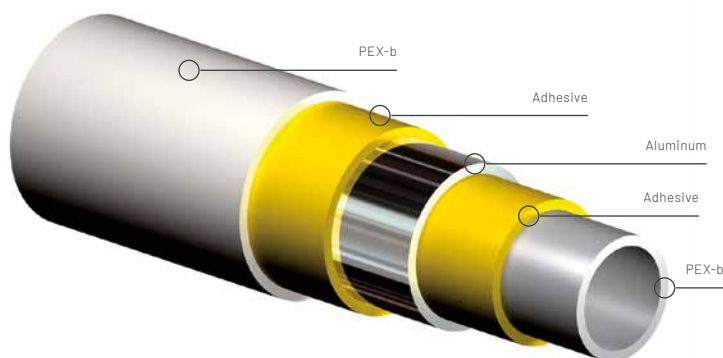
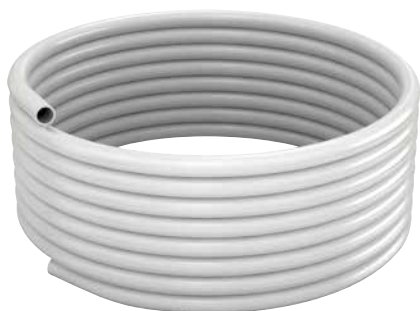

TECHINCAL DATA

R999 PEX /Al/PEX MULTILAYER PIPES

Maximum working temperature - °C: 95

Working pressure - bar: 10

Thermal linear expansion coefficient at 20 °C - 1/K: $(2,6 \cdot 10^{-5})$

Ultimate tensile strength - N/mm²: 17,6 (176 bar)

Thermal conductivity - W/mK: $\lambda = 0,4$

Internal roughness - m: $\varepsilon = 7 \cdot 10^{-6}$

Min. bending radius without pipe bender: $5 \cdot D_{e_{st}}$



ADVANCED CLIMATE CONTROL

Temperature control for every climate need.
Functional wellness and ultimate convenience
for 4-season enhanced thermal comfort.

INDOOR COMFORT CONTROL

One needs to control multiple devices in a complex system to enjoy the benefits of a radiant floor, also with heating-only installations. In a nutshell, these include:

- **heating and cooling terminals:** the radiant floor – possibly combined to a radiant wall and towel heated rails in the bathrooms – and dehumidification or HRV machines which control the room thermal balance
- **hot and cold fluid production machines (generators):** condensation boilers, heat pumps, biomass generators in appropriate technical housings
- **fluid temperature control devices:** mixing units to set the temperature of the fluids supplying the range of devices involved

Advanced climate control should properly manage indoor comfort, both in winter and summer, with air exchange and humidity control. It may include:

- room control: users can set the desired comfort conditions through room thermostats, with an optional integrated relative humidity probe
- boiler room control: based on the user's preferences set through the thermostat set-points, the electronic unit – or master controller - controls the mixing units, the generator activation and deactivation, the centralized summer/winter commutation and air treatment. The basic functions of the devices can also be integrated with optional settings.

Primary control

For primary control - or **boiler room control** to set the delivery temperature - in control systems,

Giacomini adopts different strategies, two for heating and one for cooling.





HEATING: FIXED-POINT SETTING

This is the most basic control method: constant temperature is guaranteed for the delivery fluid by setting the thermostatic valve manually.

However, there is a major limit: the user must set up the system every time the external conditions change. To satisfy this requirement, installers generally set the thermostatic valve on the project temperature (i.e. max. temperature required on the coldest winter day) and mount

electro-thermal actuators controlled by zone thermostats on the circuits. The thermostat just needs to be connected to the circulator supplying all the other circuits if no zoning is required for the heated room.

The thermostat can open the actuator by comparing the temperature set by the user with the actual one to fill the radiant circuit with hot water.



HEATING: WINTER CLIMATE COMPENSATION

Adjustment of the heating delivery temperature is provided by a **characteristic climate curve (fig. 5.1)** based on which the heat generators are required low delivery temperatures when the external one is relatively high. When the external temperature gradually drops to minimum values, the delivery temperature climbs up to the maximum value provided for by the system project. A safety thermostat prevents the

delivery water from accidentally overheating. This approach is particularly important for uninterrupted operational applications and aims at modulating the system thermal emission based on the increasing dispersion of the building or apartment. This may also enhance the heat generator output and reduce the dispersions of the distribution network to the minimum.

5.1

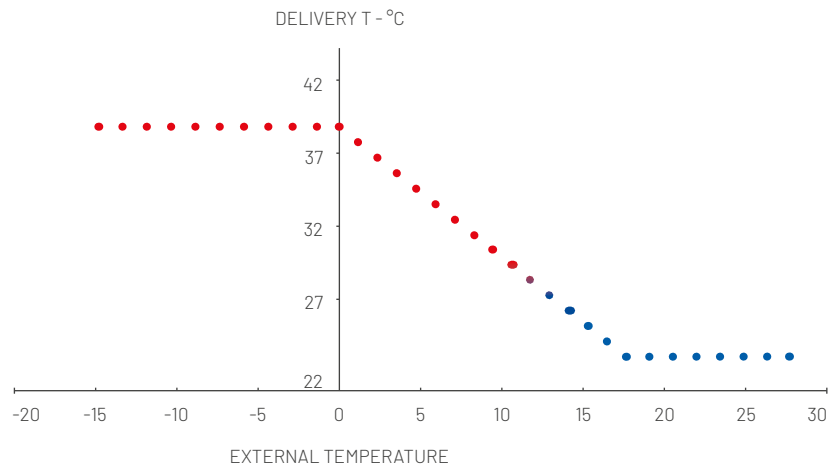

COOLING: MAXIMUM OUTPUT SET-POINT

When cooling, setting of the delivery temperature aims at finding the **value maximizing the radiant floor cooling output**.

This control technique requires thermostats with integrated relative-humidity sensors by which the user can read the dew temperature of every single room; the delivery temperature set-point is promptly set according to the highest dew temperature read so as to reach the highest output:

$$T_m = \text{Max} (T_{\min}, T_{\text{dp}} + F_s)$$

The delivery temperature T_m is then selected as the maximum value out of two: the minimum delivery temperature T_{\min} set for the controller and the highest dew temperature T_{dp} increased by an appropriate safety factor F_s .

Control systems by Giacomini

To exploit at best the radiant system, it is not sufficient to control the temperature of the water delivered to the radiant circuits centrally as this may affect the comfort levels or overheat some rooms. Needs vary based on the individual perception of heat and cold, use of the rooms, their exposition or the free external/internal energy contributions. Individual thermoregulation offers a rational and convenient solution providing the most appropriate temperature for each room or zone and combining at best comfort and energy saving. The wide range of thermostats and thermoregulation units by Giacomini covers any installation need, from basic up to the most

refined and automated systems which have become by now highly in demand for modern buildings. The range includes two different technological classes:

- the stand alone range including thermostats, chronothermostats and chronothermohumidistats able to work as units autonomous from the control units
- the klimabus range including blind probes and thermostats with relative humidity sensors part of a logic, smart and articulated system culminating with the master controller. This type of device enables radiant floors to work at best.



KLIMABUS

A field bus-based thermoregulation system to achieve top-notch performance in terms of efficiency and comfort.

The devices of this range can share information as they are wired one to the other - **the bus - to transfer messages with a dedicated encoding**. The connected devices can communicate based on their addressing. The basic diagram of reference to better understand their potential is shown in fig. 5.4.

Unit KPM30 works as master and exchanges information with the zone thermostats (up to three with the basic version KPM30Y003) through its bus. The KPM30Y003 control unit provides three output clean contacts to activate the actuators corresponding to each zone; it also exposes two clean contacts for dehumidification to integrate the dehumidifier or a fan coil. The operational set-point can also be controlled or modified through the integrated display and chronoprograms can

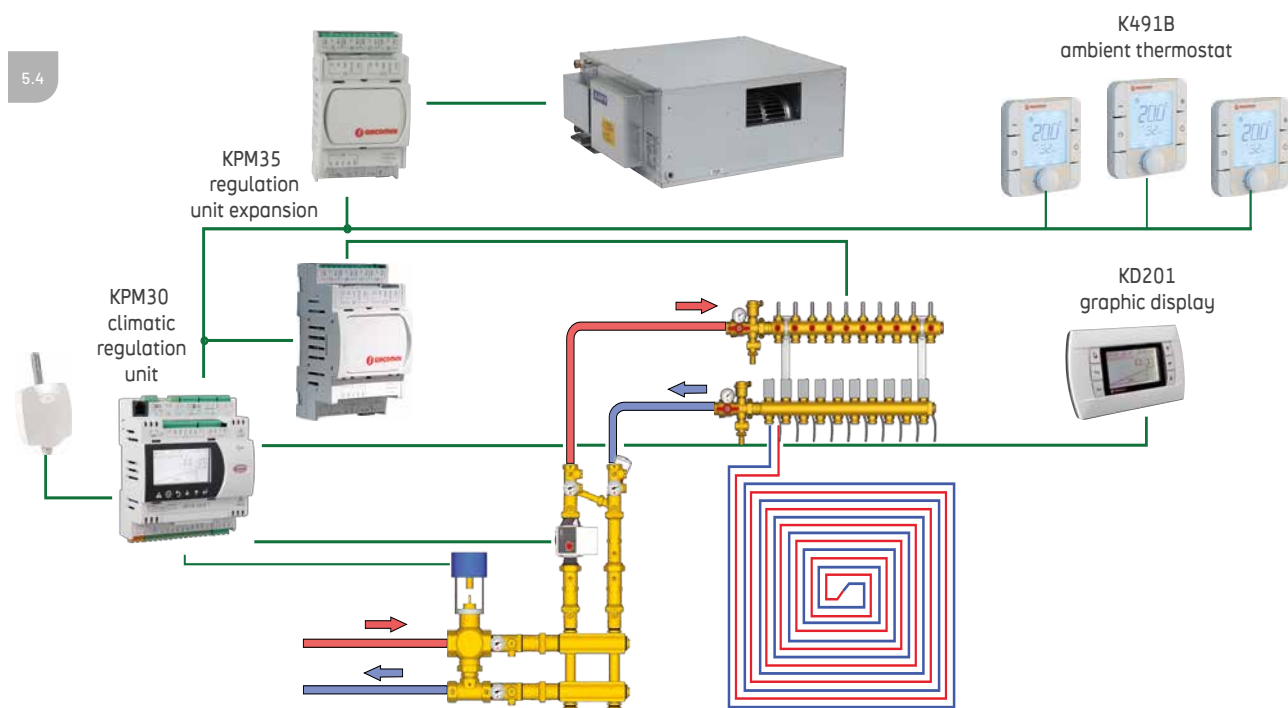

be defined and associated to each thermostat. The display-free version of the KPM31 control unit can be combined to the KD201 graphic terminal as programming interface. Management of the boiler room unit is extreme-

ly rational: the thermostats activate the mixing valve and the radiant floor circulator by interrogating the room thermoregulation unit. The thermoregulation unit reads the dew point for each of the three zones through the field bus. According

to these values it can adjust the temperature set-point of the water delivered to the radiant floor so as to enhance the output cooling power while preventing the formation of moisture.

For control of four or more zones, the field bus must be extended: each KPM30Y004 or KPM30Y005 thermoregulation unit, controlling respectively one or two mixing valves, can serve up to 16 thermostats and 7 dehumidifiers. The special KPM35 expansion modules are designed to control this type of extended systems.

This approach requires an expansion module for each pair of thermostats to control the actuators

based on a temperature signal, while other expansion modules are dedicated exclusively to the dehumidifiers (or fan coils, when installed) - based on the installation set up - according to one or multiple humidity alarm signals.

The klimabus **flexibility and potential** becomes even greater when adding special cards to the regulation modules **that make it easy to integrate other communication protocols**: thermoregulation can then become part of a more extended domotic installation enabling the user to control the system via web.

KLIMABUS BENEFITS

Extendibility



The system modularity enables to correctly size the installation and easily extend it according to the client's actual needs.

Comfort and energy saving



The "smarter" devices enhance the level of comfort and control individually each room to achieve top-notch levels of energy saving.

Communication



Every device can communicate on the bus to set up centralized functions. In addition, the end user, service operator or owner can display more information.

Versatility



The system can be configured for a variety of control methods (fixed-point or climate compensation), thus efficiently meeting the requirements of different types of buildings.

Safety



The numerous data available and the possibility to interface the bus system on site or remotely offer new opportunities to enhance its operation, maintenance and management of events and alarm signals.

KPM30 / Climate control units

DESCRIPTION

The KPM30 thermoregulation modules and the KPM35 expansion units represent the core of Giacomini's thermoregulation system. They can control both single mixing modules, for heating and cooling, and machines for dehumidification, sensible thermal power integration and HRVs.

Based on the model, they can be used in "stand alone" or "klimabus" systems.

The KPM30 thermoregulation modules include an integrated display and six multifunction buttons to program the system parameters and their

monitoring through a smart menu. The module provides rapid connection to the thermostats from the Giacomini KPM35 product range and expansions; it also controls automatically the circulator and the mixing valve servocontrol. The range includes: two "stand alone" models to control one or two mixing valves, three models compatible with the "klimabus" protocol for integrated management – combined to the KPM35 expansion modules – mixing valves (up to 2), room thermostats (1 to 16) and air treatment machines (up to 7).



👍 WHY CHOOSING IT?

- User-friendly programming
- Wide range of versions
- Optional expansions
- Configuration and monitoring through integrated graphic display (KPM30) or optional Open-end communication protocol for domotic integration

TECHINCAL DATA

Product code	Technology	N. of mixing valves	N. of room thermostats	N. of air units
KPM30Y001	Stand Alone	1	-	-
KPM30Y002	Stand Alone	2	-	-
KPM30Y003	Klimabus	1	1÷3	1
KPM30Y004	Klimabus	1	1÷16 (with KPM35)	7 (with KPM35)
KPM30Y005	Klimabus	2	1÷16 (with KPM35)	7 (with KPM35)

KPM30 / Climate control units

KPM35

Expansion module



KD201

Graphic terminal



K465P / K463P

External probe and delivery probe



KPM36

Interface card for domotic systems



CONNECTION EXAMPLE

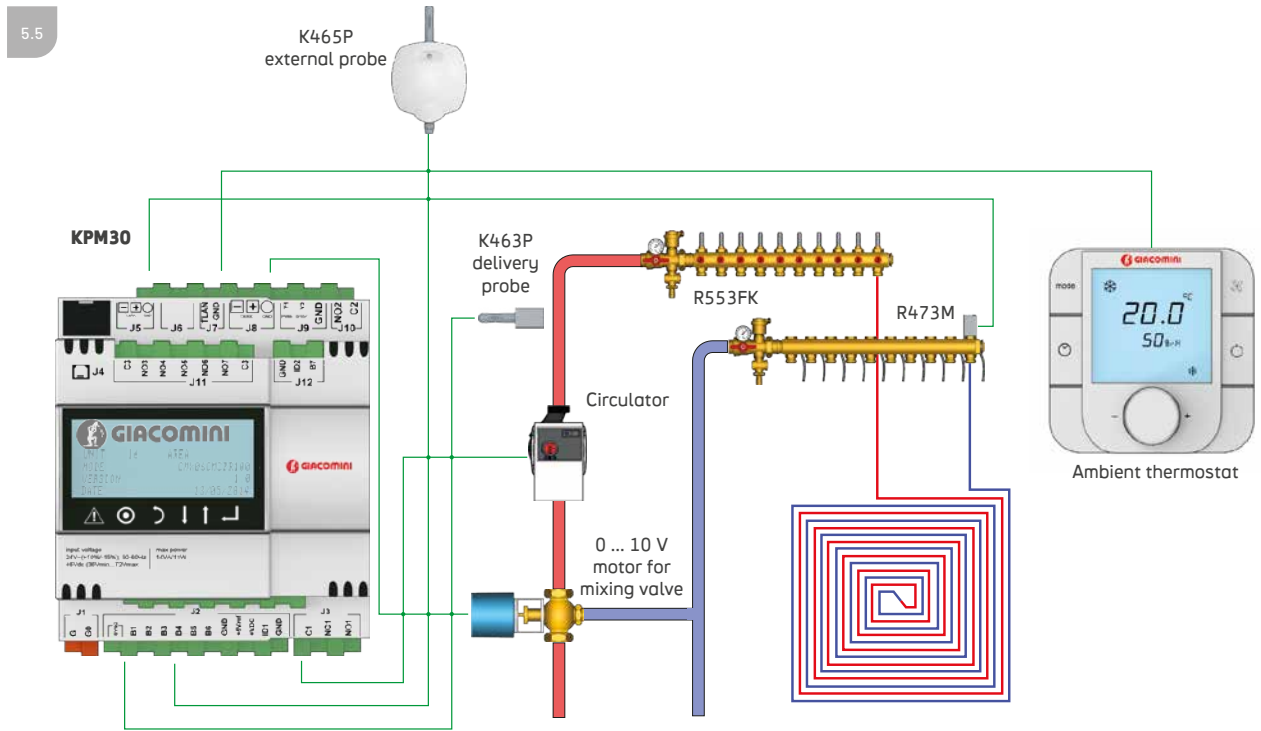

R586P / Mixing unit

DESCRIPTION

R586P mixing units control the delivery temperature of radiant systems based on the indications provided by the primary regulation devices. In addition to the mixed zone, they serve a direct non-mixed outlet as the perfect solution for radiant installations requiring an integration of high-temperature radiators in

winter or low-temperature fan coils in summer. The electronic regulation unit, sold separately, controls both heating and cooling. The available versions are all equipped with self-modulating circulators complying with the ErP 2009/125/CE directive and include motorized mixers to manage a wide range of flow rates.

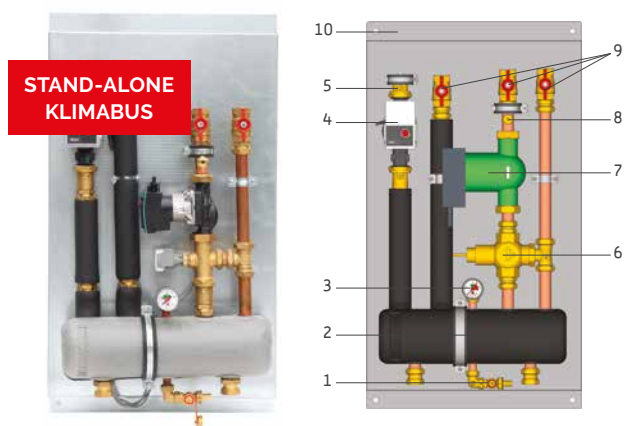

👍 WHY CHOOSING IT?

- Complete preassembled solution
- Wide range of solutions (Kv mixing valves)
- Easy to assemble

- 1 Drain cock (interchangeable with pressure gauge)
- 2 Hydraulic separator
- 3 Pressure gauge (interchangeable with drain)
- 4 Zone circulator with direct connection
- 5 Shut-off valve
- 6 Mixing valve
- 7 Zone circulator with mixed connection
- 8 Safety thermostat probe housing
- 9 Shut-off valve
- 10 Template with wall-mount fitting holes

TECHINCAL DATA

Product code	R586PY014	R586PY015	R586PY016
Primary circuit connection - " F	3/4	1	1
Primary circuit flow-rate range - m ³ /h	1 ÷ 3	2 ÷ 4	2 ÷ 5
Mixing valve DN / Kv	DN20 / Kv 5	DN25 / Kv 10	DN32 / Kv 16
Mixed connection flow-rate range - m ³ /h	0,6 ÷ 1,6	1,6 ÷ 3	3 ÷ 5
Non-mixed connection flow-rate range - m ³ /h	1 ÷ 3	1 ÷ 3	1 ÷ 3

R586R / Mixing unit

DESCRIPTION

The R586R units are preassembled modules for mixing or basic circulation which can be combined to control multiple zones of systems with temperatures from mixed delivery or non-mixed direct delivery. Highly flexible, they can be assembled in parallel to the R146IR hydraulic separator to create, for example, a mixed zone and one with direct connection. When positioned upstream, they can work as re-launching units – combined to the R586I special modular connection unit – for multiple

mixed zones deriving from the same K297R mixing unit. Just like the R586P units, they can be combined to an electronic thermoregulation unit – sold separately – for both heating and cooling. The version equipped with fixed-point mixing through thermostatic actuator is available for heating only. To enjoy top-notch levels of energy efficiency, all available versions include self-modulating circulators complying with the ErP 2009/125/CE directive and a cross-linked polyethylene foam insulation shell.

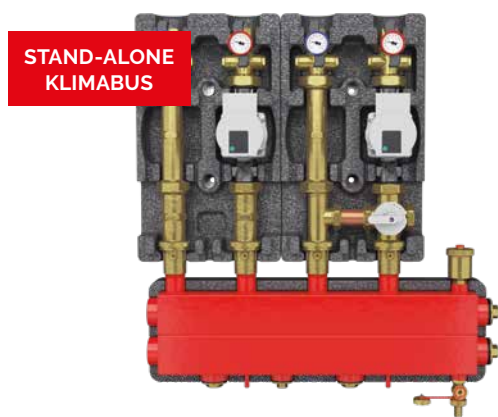

👍 WHY CHOOSING IT?

- Complete preassembled solution
- Compact dimensions
- Optional expansion
- Flexibility of use

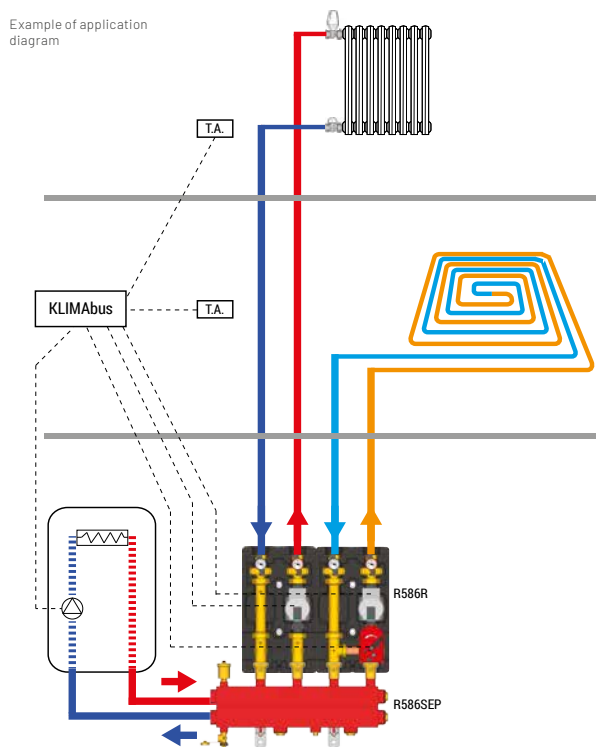

K492B / Room thermostat

DESCRIPTION

The K492B thermostat enables users to control the local temperature and humidity by means of a temperature and humidity probe. The set-point can be adjusted in an easy and intuitive way using the front knob. It requires bus

connection with regulation modules KPM30 or KPM31. Voltage 230 Vac. The K492B Thermostat can be used with the most popular wall flush-mount boxes available on international markets (type 502, Ø 65 mm and min. depth 31 mm).*



👍 WHY CHOOSING IT?

- Product for semi-flush mounting
- User-friendly display
- Easy to use
- Equipped with temperature and humidity sensor

CONNECTION DIAGRAM

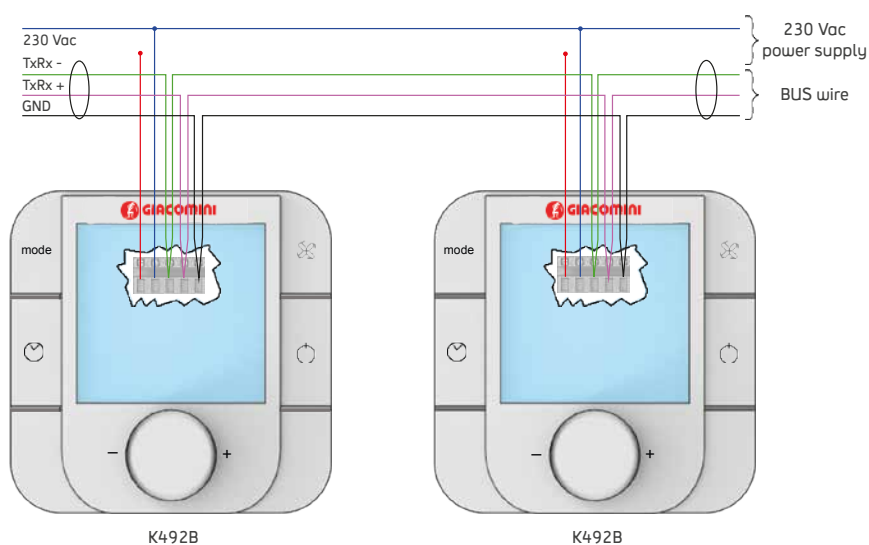

K492L / Room thermostat

DESCRIPTION

The K495L thermostat with temperature and humidity sensor controls heating and cooling systems when combined to a KPM30 or KPM31 regulation module: the thermostat communicates the room temperature and relative humidity to the regulation module through bus connection. Voltage 24 Vac.

The K495L Thermostat can be installed on an Italian standard 3-module wall-mount box (type 503) or directly on the wall with screws and screw anchors.

The user can read and set the desired room temperature directly on the back-lit display or centrally from the regulation module.



👍 WHY CHOOSING IT?

- Wall-mounting
- Easy to use (+/- button)
- Equipped with temperature and humidity sensor

CONNECTION DIAGRAM

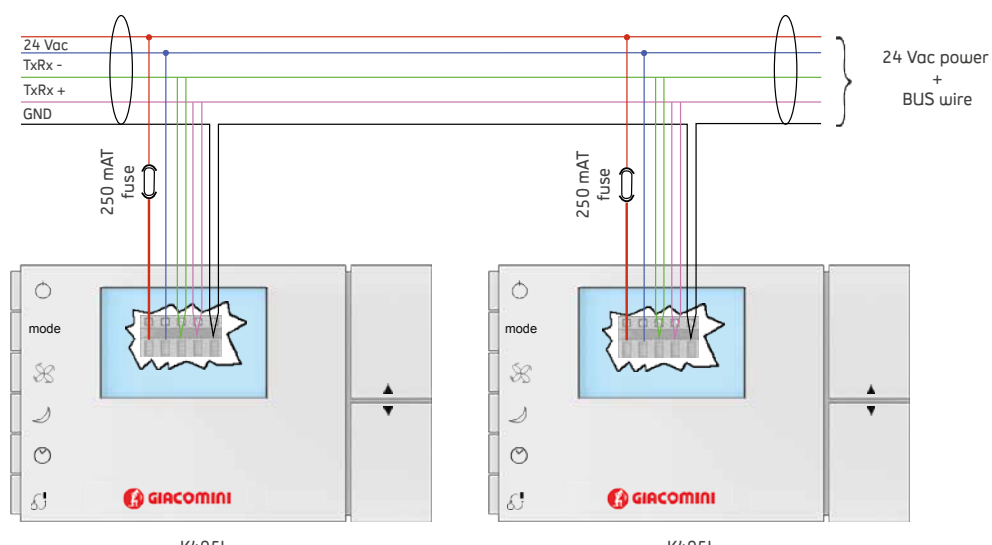

K493T / Touch thermostat

DESCRIPTION

The K493T thermostat with temperature and humidity sensor controls heating and cooling systems through bus connection with a KPM30 or KPM31 regulation module. Voltage 12 Vac. Featuring the same functions of K492B and

K495L, it also includes a winning user-friendly "touch" display which makes all set-up and display operations even easier. For wall or semi-flush mounting on standard 3-module box (type 503).

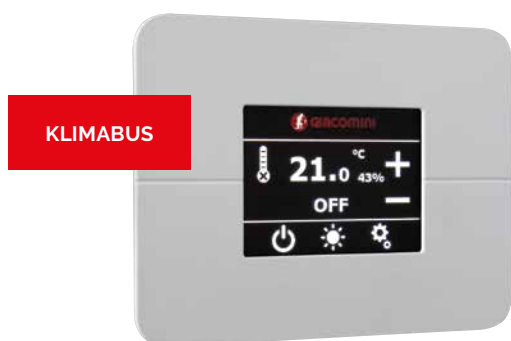

👍 WHY CHOOSING IT?

- Touch display
- Winning design
- Easy to use
- Equipped with temperature and humidity sensor

K495B / K493I / Blind probes

DESCRIPTION

The K495B and K493I Blind probes work as thermohumidistats for all heating and cooling applications where no local temperature/humidity set-up and display is required. "All parameters can be entered or monitored through the KPM30

regulation module (or KPM31 combined to the KD201 display) to which the blind probe is connected through field bus. K493I requires flush-mounting installation on civil hole covers.



👍 WHY CHOOSING THEM?

- the perfect solution to prevent direct modification of the parameters (school, public offices, etc.)
- Compatible with all flush-mount civil ranges (K493I)

K373 / Safety thermostat

DESCRIPTION

The K373 device works as a limiting thermostat for overheating of radiant floor systems: should the delivery water temperature exceed the pre-set limit in case of operational anomalies, the thermostat sends out a signal (clean contact) which can be used to block the circulator. This is a safety device, provided for by the technical standard, which must function also in case of power blackout. The K373 safety thermostat includes an immersion probe, LEDs as visual alarms of the operational status and automatic reactivation. The triggering temperature can range between 40÷80 °C (factory setting 50 °C). Network voltage 230 Vac.



Thermo-electric actuators

DESCRIPTION

The need for state-of-the-art temperature control of single rooms is fulfilled by using thermo-electric actuators installed on the distribution manifolds to shut off every single circuit. They can be fitted directly on stand-alone thermostats or integrated in klimabus thermoregulation systems (and therefore controlled through KPM30 or KPM31 thermoregulation units).

There are two versions available:

- normally open: the circuits are supplied

hydraulically when power is down. These are the R478 (with 2-thread power wires) and R478M (with 4-thread power wires and micro-limit switch) heads

- normally closed: the circuits are supplied hydraulically when power is on. These are the R473 (with 2-thread power wires) and R473M (with 4-thread power wires and micro-limit switch) heads.



👍 WHY CHOOSING THEM?

- Individual shutting off of every circuit
- Individual temperature control of every room
- Wide range of versions
- Easy to assemble
- Extremely quiet

EXAMPLE OF THERMO-ELECTRIC ACTUATOR CONNECTION DIAGRAM

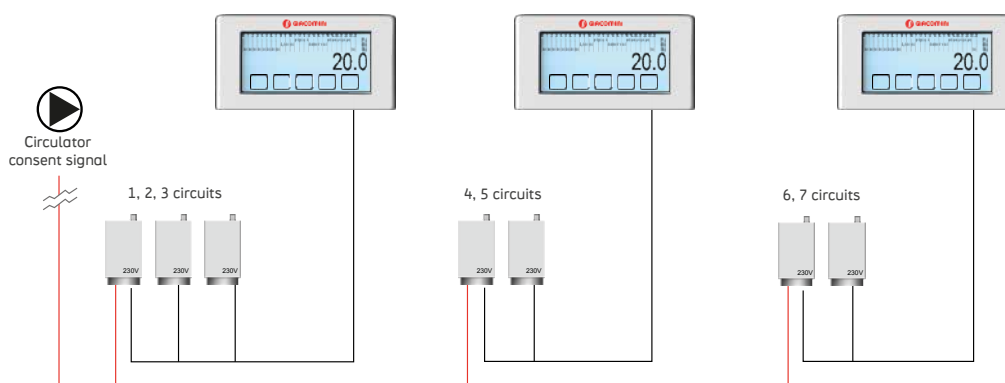

K490I / Chronothermostat

DESCRIPTION

K490I is a "stand alone" digital electronic chronothermostat with weekly programming to control heating and cooling systems. Available in two versions: battery-powered and electric-powered. Designed for installation in flush-mounting 3-module boxes, it can be matched to

a wide range of covers, frames and adaptors to apply plates from the most popular civil ranges. Connection to a GSM phone activator (K499 optional) enables to program and control the room temperature also remotely.



👍 WHY CHOOSING IT?

- Weekly programming
- Back-lit LCD display
- Refined design
- Compatible with the most popular civil ranges

K494I / K494 / Thermostat

DESCRIPTION

The K494 and K494I thermostats are “stand alone” devices to control the room temperature of heating and cooling systems.

K494I for flush-mounting installation in 3-module boxes is available in the battery-powered version

(winter-only control) or 230Vac-powered version (summer/winter control). K494 for exposed wall-mount installation is available in the battery-powered version only.



👍 WHY CHOOSING THEM?

- Great quality-price ratio
- Easy to use
- Compatible with the most popular civil ranges (for flush-mounting version K494I)

CONNECTION DIAGRAM FOR K492D WITH THERMO-ELECTRIC ACTUATORS AND DEHUMIDIFIERS

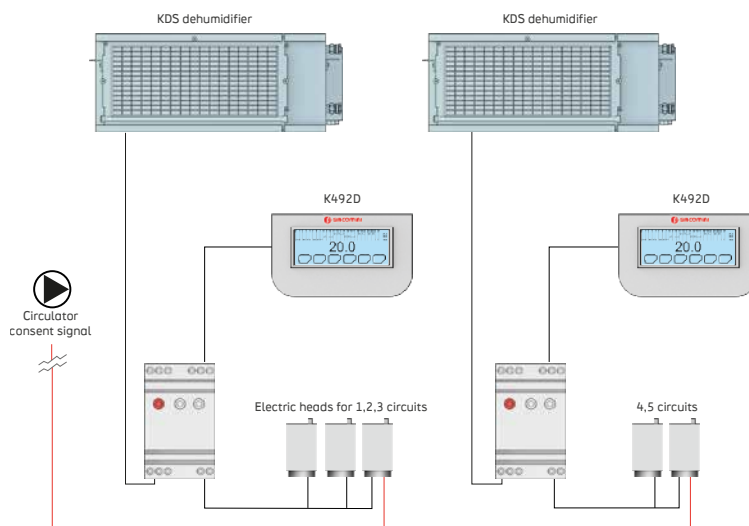

K492D / Chronothermostat with humidistat

DESCRIPTION

The K492 range, which includes K492D with integrated relative-humidity sensor, features "stand alone" weekly chronothermostats for exposed wall-mount installation with a large touch-screen display. All models can control the thermo-electric actuators for room thermoregulation.

The integrated humidity probe makes this product particularly suitable for control of cooling systems. With its special exposed module, K492D can also control the dehumidifiers. In addition, it can be combined to the "stand-alone" versions of the KPM30 or KPM31 control units.



👍 WHY CHOOSING IT?

- Weekly programming
- Humidity sensor included
- Dehumidifier control (K492D)

KLIMAdomotic thermoregulation / Room control

A COMPLETE PLATFORM TO CONTROL INDOOR COMFORT

KLIMAdomotic is an enhanced smart control system for radiant panel or thermoregulation systems with remote-control (wireless) thermostatic valves. It enables to control every element of indoor comfort - from heating to summer air conditioning, air exchange and humidity control - through one single user interface.

The KD410 Connect control unit is set up based on the system installed. The product will have a

software version specific for the different types of installations: Connect-Rad for radiant systems and Connect-TRV for thermoregulation systems with thermostatic valves. With KD410 Connect, the user is connected to his system 24/7: easy to set up thanks to the user-friendly graphic interface, it can be controlled remotely with most smartphones through the "Giacomini Connect" dedicated app.

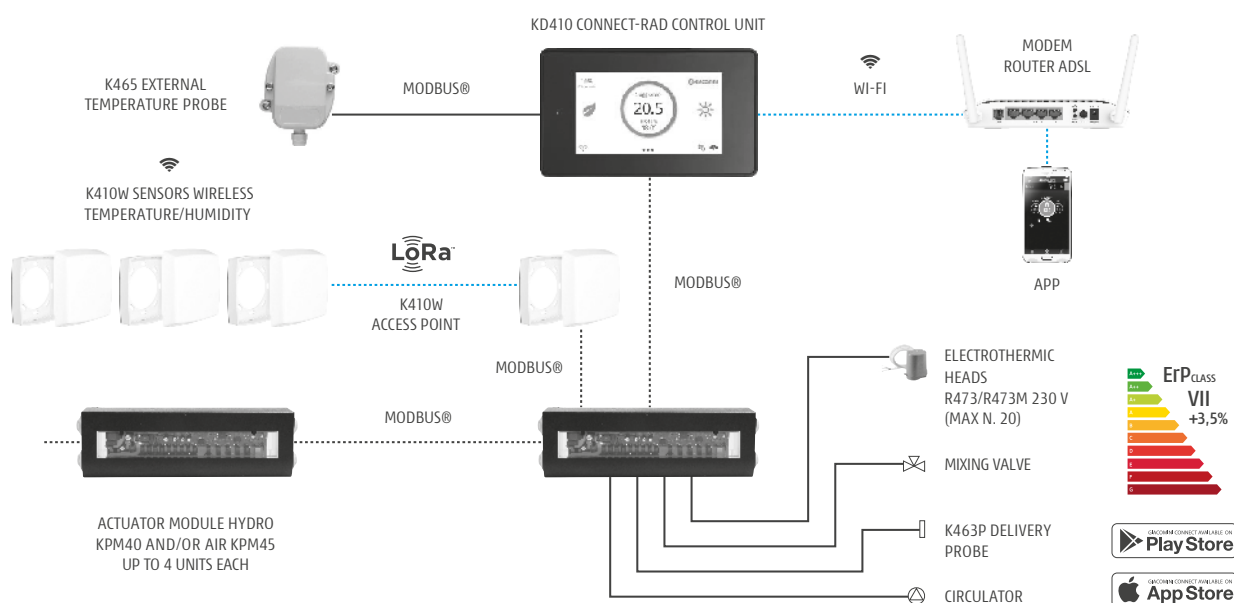

STAND ALONE

The stand-alone regulation system is characterized by an interface between primary – in the boiler room – and secondary regulation inside the room; this is achieved through basic exchange of a clean contact. Diagrams of fig. 5.2 and 5.3 clearly show this feature.

The strategy provides for separation of room control from boiler room regulation. The room is equipped with a chronothermohumidistat which provides for master functions and activates the dehumidifier in addition to adjusting its zone temperature; other thermostats control the temperature of

the corresponding zones. Should the system be installed in an apartment with a heat metering module, the master chronothermohumidistat can also turn ON/OFF the zone valve installed in the metering module itself. The thermoregulation unit turns ON/OFF the circulator and controls the mixing valve serving the radiant system.

Its simplicity represents the true value of this thermoregulation technique: a limited number of devices successfully controls a complex system. However, this approach prevents the radiant floor from expressing its maximum power when cooling.

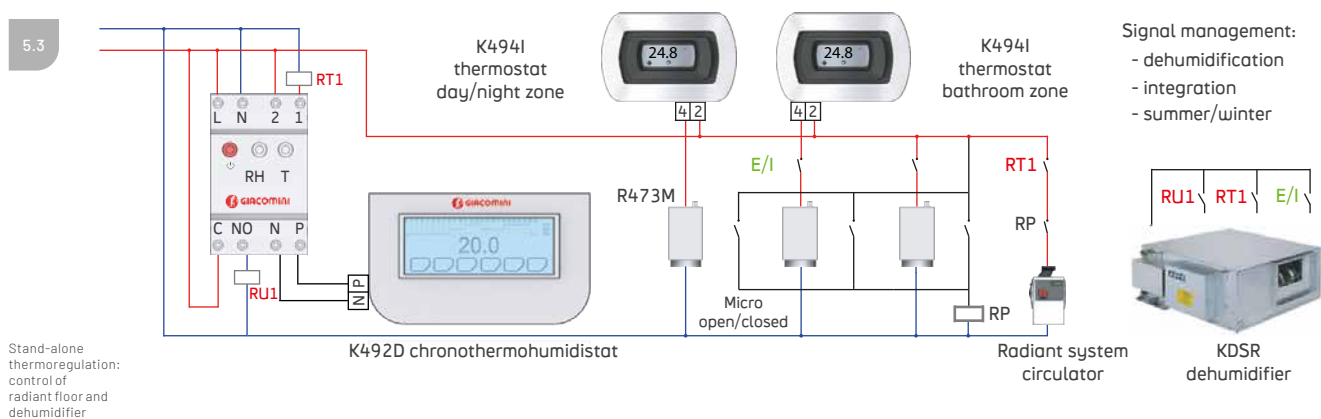
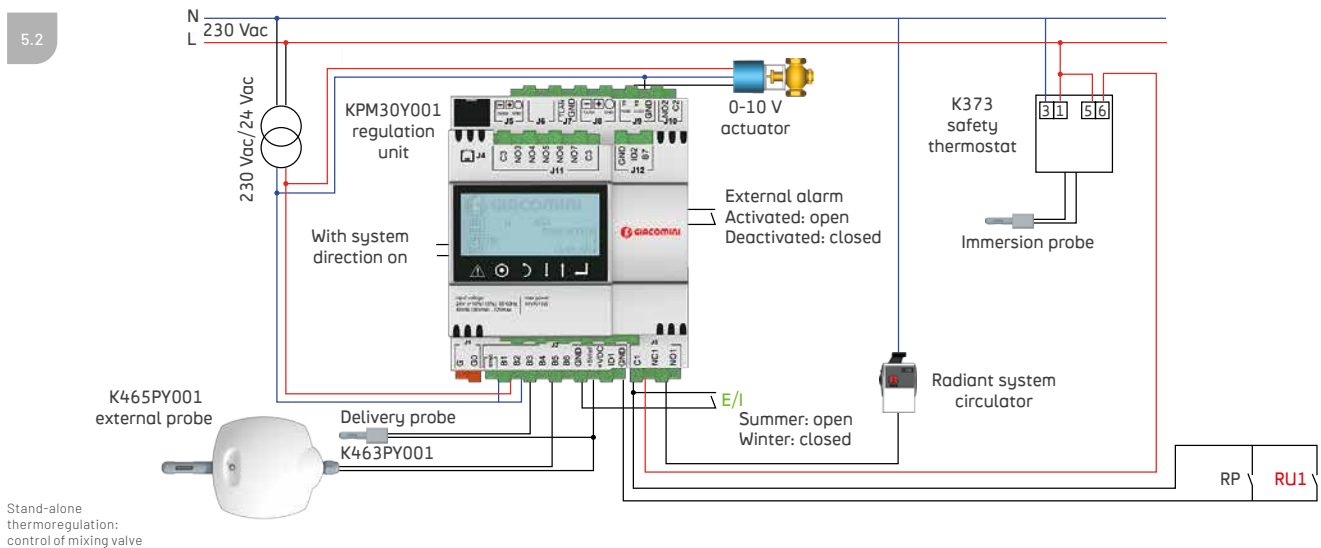

K492T

The new K492T thermostat is a Wi-Fi weekly chronothermohumidistat with back-lit touchscreen. The white unit can be installed on the wall or on a 503 3-module civil box. Based on the version, it can control thermo-electric actuators, dehumidifiers and fan coils. Powered at 230 V. Programmable for weekly, daily and manual operation, both for heating

and cooling, with an integrated sensor to read relative humidity. The K-Domo dedicated app is available for remote control.

Compatible with "Termostato Wi-Fi Giacomini" by Alexa and Google Home



👍 WHY CHOOSING IT?

- Extremely easy to use
- Voice and App control
- Appealing design
- Optional control of fancoils or dehumidifiers

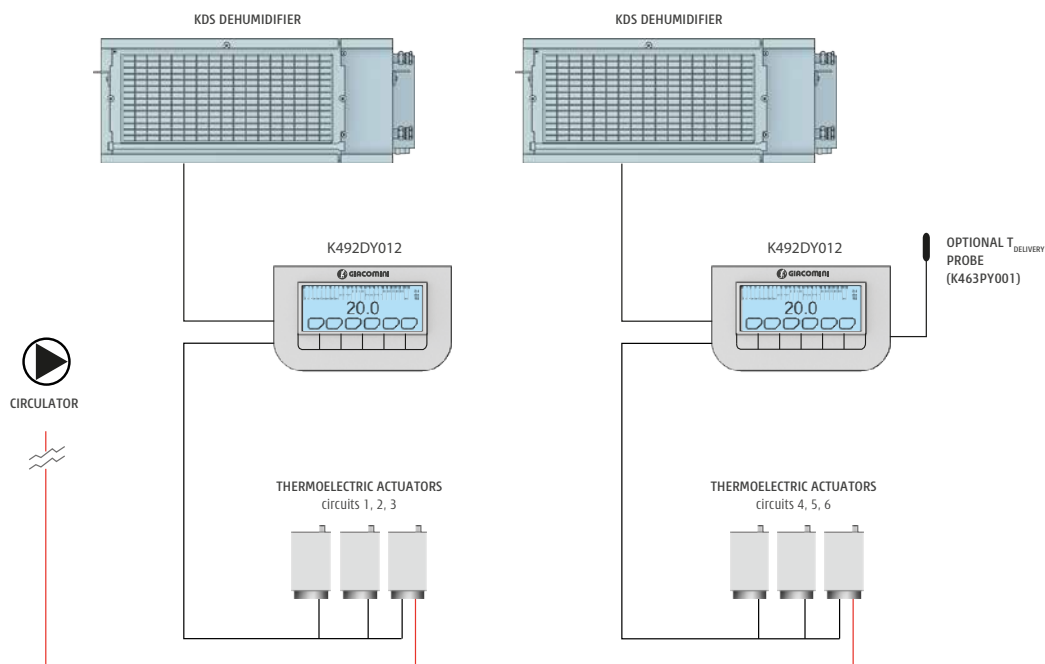

Connection diagram for K492DY012 with thermo-electric actuators and dehumidifiers





COOLING AND AIR TREATMENT

Embracing warmth in winter. State-of-the-art cooling in summer. The utmost comfort year round. With temperature and humidity always under control, cooling solutions guarantee the best climate quality in every room.

RADIANT COMFORT YEAR ROUND

In an ever-changing real estate market, high energy efficiency classes achieved with enhanced insulation systems are a must for modern buildings. This advanced type of insulations call for control of summer temperatures, humidity and air quality of the occupied rooms.

Summer cooling is by now essential in modern air conditioning systems, including residential ones. While in winter one just needs to increase the temperature through the heating system - the level of humidity is already adequate and doesn't require

specific control - in summer both temperature (cooling) and humidity (dehumidification) need to be reduced to prevent discomfort, ideally by avoiding sudden temperature changes between the inside and the outside and guaranteeing the required protection against condensation⁽¹⁾.

A radiant floor system, combined to units designed specifically for air dehumidification, is a winning option to achieve the ideal thermohygrometric comfort and significant energy saving ratios along the entire annual cycle of occupancy.

(1) According to standard EN ISO 7730, relative humidity should not exceed 60-65 % to provide a sensation of comfort and guarantee healthy indoor air at all times. In summer, sanitary authorities generally recommend a 7-8 °C difference between the external and the indoor temperature.



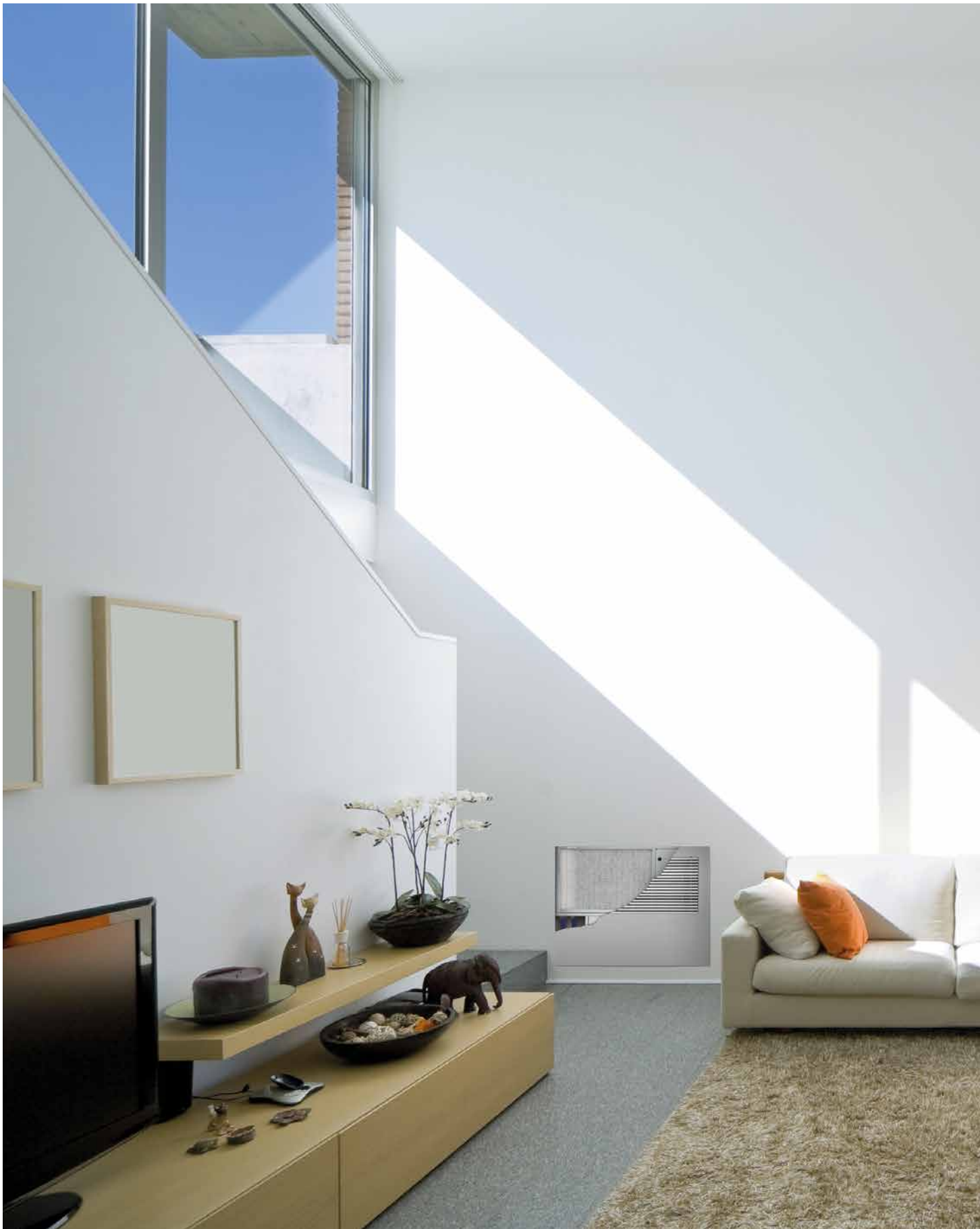

AIR TREATMENT / DEHUMIDIFICATION WITH OR WITHOUT INTEGRATION



“Air treatment” refers to the control of indoor thermo-hygrometric conditions through dehumidification and cooling. Air exchange and heat recovery are not provided.

OPERATIONAL PRINCIPLE OF AIR TREATMENT UNITS

Basic air treatment units reduce indoor humidity only and are known as isothermal dehumidifiers. Schematization of an isothermal dehumidifier is given in Fig. 1.

This type of machine vacuums and filters indoor wet air (1) (generally at a 26-27 °C temperature), which is then cooled down by a hydronic coil (2) supplied with water at approx. 15-18 °C.

The cooling stage brings the wet air as close as possible to condensation using the water already available to supply the radiant floor, with no additional work required from the cooling circuit electric compressor. The cooled air is now ready to flow through the cooling circuit evaporation coil (3): it is during this phase that it releases humidity by condensation. The resulting air features a humidity percentage lower than the room humidity, suitable for introduction into the room itself. Prior to the intake phase, air passes through the condensation coil (5, left side): the air temperature is exploited to condensate the cooling fluid so as to repeat

the cycle. However, the resulting air is warmer by effect of the condensation heat from the fluid, useful to make it flow through a second post-cooling hydronic coil (5, right side) which brings it back to a temperature not exceeding the one it featured when entering the unit. In the final phase, the air is channeled into the room.

With a slight variation to the diagram of the machine described above, one obtains a **dehumidifier with sensible cooling integration** and a dual function: work as an isotherm dehumidifier or as a machine able to integrate sensible cooling by introducing air cooler than the inflow. Compared to the isotherm dehumidifier, diagram of Fig. 2 shows a dual condenser in the cooling circuit: next to the condenser interacting with air (3), there is another one (5) dispersing the condensation heat in water. When this happens, that is when the unit works with integration, the air condenser (3) is blocked and dry fresh air can be introduced into the room.



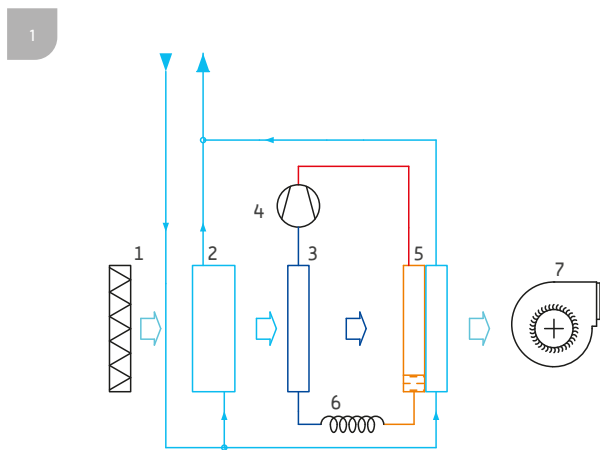

Schematization of an isotherm dehumidifier.

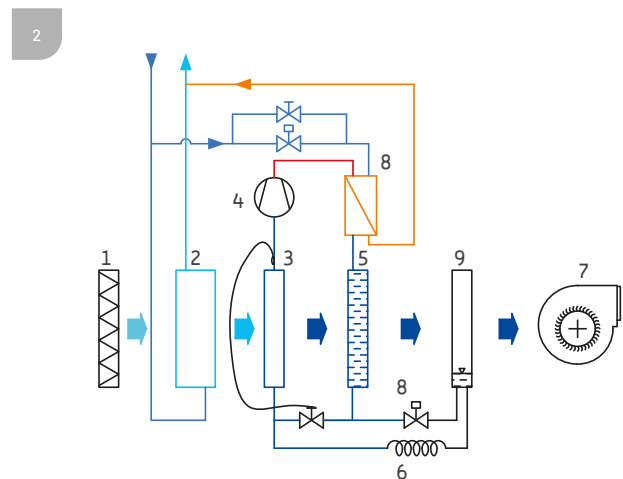

Schematization of a sensible integration dehumidifier.

THERMODYNAMIC OR HYDRONIC INTEGRATION

In addition to dehumidification, air treatment and HRV units can feature sensible integration in summer to meet the needs of zones with greater thermal loads.

Units with **thermodynamic integration** include a cooling circuit to provide air cooling along with

dehumidification. Units with **hydronic integration** and no cooling circuit include a hydronic coil that provides, along with air dehumidification, summer cooling (delivery +7 °C, return +12 °C) or winter heating (delivery +50 °C, return +40 °C).

OPERATIONAL PRINCIPLE OF A HEAT RECUPERATOR WITH DEHUMIDIFICATION AND THERMODYNAMIC INTEGRATION.

According to the dehumidifier operational principle explained above, the benefits offered by thermodynamic integration units are straightforward:

- they work on water at 15-18 °C, the same temperature required by cooling radiant systems, and enable cooling units to work at water temperatures higher than the traditional 7 °C of hydronic air conditioning systems, with great benefits in terms of energy efficiency (EER - Energy Efficiency Ratio)

- their high latent power/air flow rate ratio - up to 2,5 W per m³/h - cuts down the quantity of air required to cover latent loads, resulting in quietness, no drafts and minimum consumption of electric energy

In addition to dehumidification and integration of sensible thermal power, heat recovery ventilation units (HRV) provide air exchange with high-efficiency heat recovery. They represent the most complete machines for indoor air treatment and, as expected, they are the ideal solution for

continuous operation year round.

These units have the same cooling circuit of the one described for sensible integration dehumidifiers: they include two condensers, a post-heating condenser and a dissipation condenser. We will use two units by Giacomini, KDVRW and KDVRA, to explain their operational principle. They differ for their inner layout and dissipation condenser: a water condenser for KDVRW and an air condenser for KDVRA.

As shown by the diagrams of Fig. 3, before being transferred into the treatment coils, the external air (exchange) in both units is pre-cooled in an air-air recuperator (1) by exchanging it with foul air which is ejected from the room. When leaving the recuperator, it is mixed with the recirculation

air and undergoes initial sensible cooling inside the water-fed finned coil (3), right after cooling and dehumidification in the cooling evaporator (4) and post-heating in the condenser (5). Finally, the delivery fan channels it into the room.

The dampers (10, 11, 12) modulate the recirculation and external air flow rates to reach the flow rate desired for the room air and foul air - to be ejected after recovery - which flows are triggered by the exhaust fan (8).

The KDVRA unit the dissipation condenser (6) is cooled through the extraction air flow combined, when necessary, to an additional flow of external air. On the contrary, condensation heat in the KDVRW unit is disposed of in water through a plate exchanger.

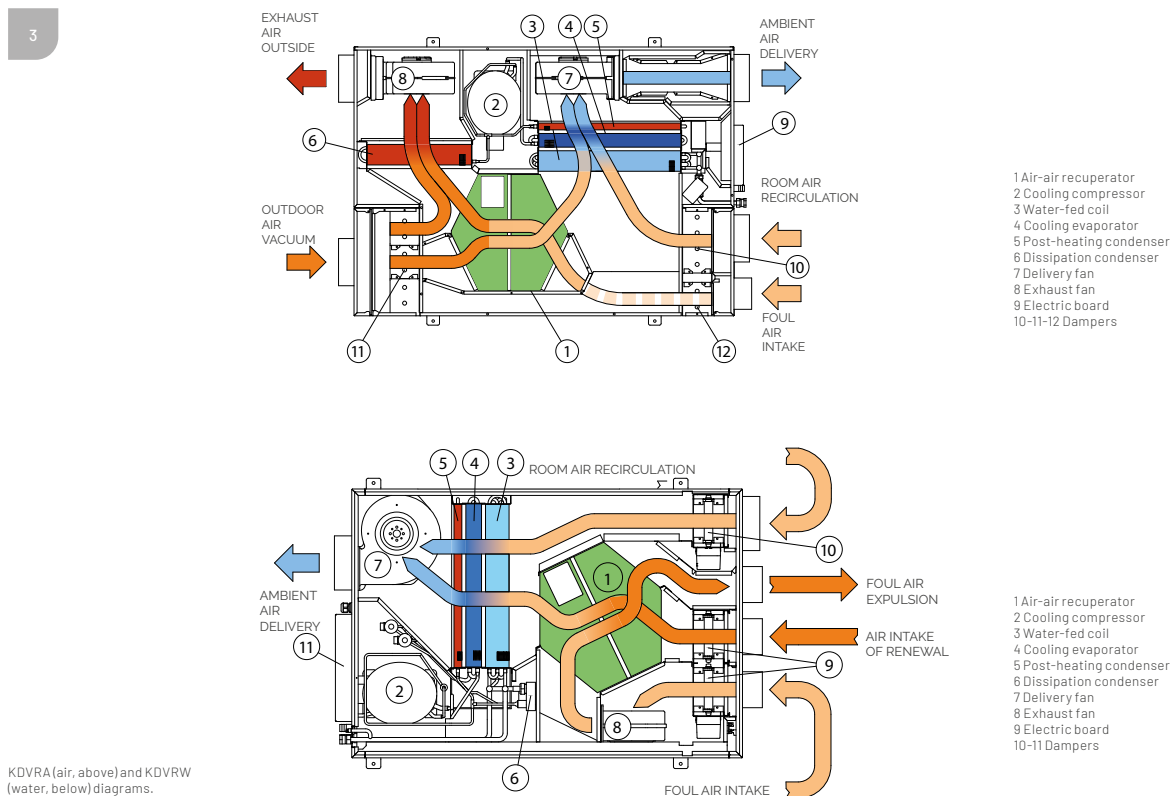

COOLING AND AIR TREATMENT

Summer cooling is by now essential in modern air conditioning radiant systems, including residential ones. While in winter one just needs to increase the temperature through the heating system, in summer both temperature (cooling) and humidity (dehumidification) need to be reduced to prevent discomfort, ideally by avoiding sudden temperature changes between the inside and the outside and guaranteeing the required protection against condensation. A radiant floor system, combined to units designed specifically for air dehumidification, is a winning option to achieve the ideal thermohygrometric comfort and significant energy saving ratios along the entire annual cycle

BENEFITS

There is a variety of benefits offered by dehumidification units:

- they work on water at 15-18 °C, the same temperature required by cooling radiant systems, and enable cooling units to work at water temperatures higher than the traditional 7 °C of hydronic air conditioning systems, with great benefits in terms of energy efficiency (EER - Energy Efficiency Ratio)
- their high latent power/air flow rate ratio - up

of occupancy. Giacomini has designed a full range of dehumidification solutions for radiant systems, including high-efficiency machines, for wall flush mounting (KDP) or duct-type suspended ceiling flush mounting (KDS) that provide dehumidification only (isotherm dehumidifiers) or integration of sensible power and primary air treatment (dehumidifiers with sensible cooling integration). KDV represents the top of the range, available with water or air dissipative condenser: in addition to dehumidification and sensible thermal power, it also provides air exchange, with or without heat recovery, and free-cooling, thanks to a high efficiency air-air heat recuperator.

to 2,5 W per m³/h - cuts down the quantity of air required to cover latent loads, resulting in quietness, no drafts and minimum consumption of electric energy

Giacomini thermoregulation controls the entire cooling system by adjusting on a constant basis the water and air temperature, along with indoor humidity, and activating the dehumidification units when needed.

IN A NUTSHELL

HRV systems



Heat Recovery Ventilation in Giacomini systems is generally represented by a Centralized Dual-Flow HRV: the ventilation unit, known as heat recuperator, provides air exchange through special ducts in adjoining rooms by extracting exhaust air and introducing fresh air with heat recovery.

Air treatment is also available as optional (dehumidification with or without sensible integration).

As for basic flow systems, only those with decentralized or alternated single-flow pinch-point heat recuperators and extraction pinch-point fans (decentralized HRV) are described herewith.

Safety and comfort



- No drafts and sudden thermal changes
- Noiseless and no insects from the outside, as rooms are ventilated with closed windows
- Limited house breaking for open windows
- Exhaust of indoor odours
- Control of indoor humidity
- Noiseless operation, also during the night
- Ideal indoor climate combined to the radiant system
- Safety against condensation of radiant air conditioning systems
- Adapts to seasonal climatic conditions

Hygiene and health



- Continuous and autonomous air exchange
- Control of indoor pollutants
- Reduction of pollutants from the outside (particulates)
- No proliferation of mold caused by humidity contained in air
- Healthy and comfortable indoor climate, guaranteed day and night
- Improved indoor climate for users with allergies or individuals with breathing problems

Energy-saving and eco-friendly



- Limited heat dispersions
- Thanks to the energy recovery, the heating and air conditioning devices can have more compact dimensions
- Sensible and latent heat recovery of exhaust air enables to limit the heating and cooling system activation
- Efficient use of energy and a resulting reduction of polluting emissions
- Cooling circuits with next-generation cooling fluids to guarantee greater energy efficiency and protect the environment
- Ventilation system repaying itself in time through energy saving
- Enhanced energy performance of the building
- Increased value of the building maintained in time
- Tax relief benefits according to the laws in force



KHR / VENTILATION UNITS

KHR machines are HRV units for freestanding (KHR-V), suspended ceiling (KHR-H) or wall-mount (KHR-Z) installation. They are duct-type machines fit for air exchange in multiple rooms. They basically consists of a high-efficiency dual-flow heat recuperator. The self-supporting monoblock structure includes a single galvanized metal sheet panel combined to

a polyethylene pad (thickness 10 mm) for thermal insulation and soundproofing.

Its radial centrifugal fans feature reverse blades and EC speed modulation motors to enjoy high efficiency, low consumptions and reduced noise. All ventilation units by Giacomini can work in free cooling mode with a motorized damper.



KDP / KDS DEHUMIDIFICATION AND INTEGRATION UNITS

KDP and KDS machines are monoblock units for wall (KDP) or suspended ceiling (KDS) flush-mounting installation. The suspended ceiling version is a duct-type machine, the perfect solution for air treatment in multiple rooms.

Its basic elements include a removable filtering unit, a cooling unit (with pre- and post-treatment coil), a finned exchanger and a centrifugal fan. The machine structure is made with galvanized metal sheets coated with soundproofing material.

The KDP wall-mounting units include a metal counter-case and a front white lacquered wood panel. Along with dehumidification, specific models offer sensible power integration for the air conditioned rooms: in this case, the temperature of the outflow air is cooler than the inflow.



KDV DEHUMIDIFICATION AND HEAT RECOVERY VENTILATION UNITS

KHRD and KHRW machines are dehumidification, integration and primary air treatment units. They are fit for duct-type installation inside the suspended ceiling and include a high-efficiency air-air heat recuperator.

They also include a removable filtering section, two centrifugal fans, five motorized dampers (for delivery, recirculation, extraction, fresh air intake, ejection), cooling circuit and exchange coils. Based on the model, they feature hydronic or thermodynamic integration. The inflow air can consist of two flows: the exchange air and the air recirculation, with rates varying based on the type of treatment required for inflow air.

The air flow rates can be set through the control panel.

The basic characteristics of the machine are: summer and winter air exchange with high-efficiency heat recovery, summer dehumidification with temperature control of inflow air, operation with water at the same temperature required by the radiant floor - 15-18° C in summer, 35-40° C in winter - foul air extraction, room air recirculation with free cooling control (KDVRAY300 only), inflow air temperature set through the control panel, possibility to set operational times when the machine is off, separation from the outside by closing the dampers.



HEAT RECUPERATOR RAPID-SELECTION TABLE

Building surface	Type of lodging	Exchange air flow rate calculated*	Heat recuperator			Heat recuperator with air treatment		
			Type	Nominal flow rate	Air treatment catalog page	Type	Nominal flow rate	Air treatment catalog page
Up to 50	Studio flat, two-roomed flat, 1 bathroom	max 70	KHR-V	200 m ³ /h	page 42	KHRD-V KHRD-H KHRW-V KHRW-H	300/150 m ³ /h 300/150 m ³ /h 300/150 m ³ /h 300/150 m ³ /h	page 60 page 65 page 82 page 87
50÷60 60÷70 70÷80 80÷90	Living room, kitchen 1-2-3 bedrooms 1-2 bathrooms	75 90 105 115	KHR-V	200 m ³ /h 200 m ³ /h 140 m ³ /h	page 42	KHRD-V KHRD-H KHRW-V KHRW-H KHRW-H KDV water cond.	300/150 m ³ /h 300/150 m ³ /h 300/150 m ³ /h 300/150 m ³ /h 600/150 m ³ /h 300/160 m ³ /h	page 60 page 65 page 82 page 87 page 87 page 70
90÷100 100÷110 110÷120 120÷130	Living room, kitchen 2-3 bedrooms 2 bathrooms	130 145 160 170	KHR-V	200 m ³ /h 200 m ³ /h 200 m ³ /h	page 42	KHRD-V KHRD-H KHRW-V KHRW-H KDV air cond.	500/250 m ³ /h 500/250 m ³ /h 500/250 m ³ /h 500/250 m ³ /h 360/220 m ³ /h	page 60 page 65 page 82 page 87 page 70
120÷130 130÷140 140÷150 150÷160	Living room, kitchen 2-3-4 bedrooms 2-3 bathrooms	170 185 200 210	KHR-V	300 m ³ /h 300 m ³ /h 300 m ³ /h	page 42	KHRD-V KHRD-H KHRW-V KHRW-H KDV air cond.	500/250 m ³ /h 500/250 m ³ /h 500/250 m ³ /h 500/250 m ³ /h 500/300 m ³ /h	page 60 page 65 page 82 page 87 page 70
160÷170 180÷200 200÷220	Living room, kitchen 2-3-4 bedrooms 2-3 bathrooms	225 260 285	KHR-V	400 m ³ /h 400 m ³ /h	page 42	KHR-V + split modules KMSD or split modules KMSW	400 m ³ /h 400 m ³ /h	page 42 page 73 page 92
220÷250 250÷280	Large residential units, multi-lodging, small tertiary unit	320 360	KHR-V	500 m ³ /h 500 m ³ /h	page 42	KHR-V + split modules KMSD or split modules KMSW	500 m ³ /h 500 m ³ /h	page 45 page 83 page 104

*The volume of inflow air is calculated based on standard UNI EN 832 - UNI 10339, with values corresponding to 0,5 volumes/h referred to the lodging volume (standard internal height 2,7 m).



1 - Dehumidifiers



2 - Plenums for room openings and grids



3 - Ducts, fittings, accessories



AIR DEHUMIDIFICATION/ INTEGRATION

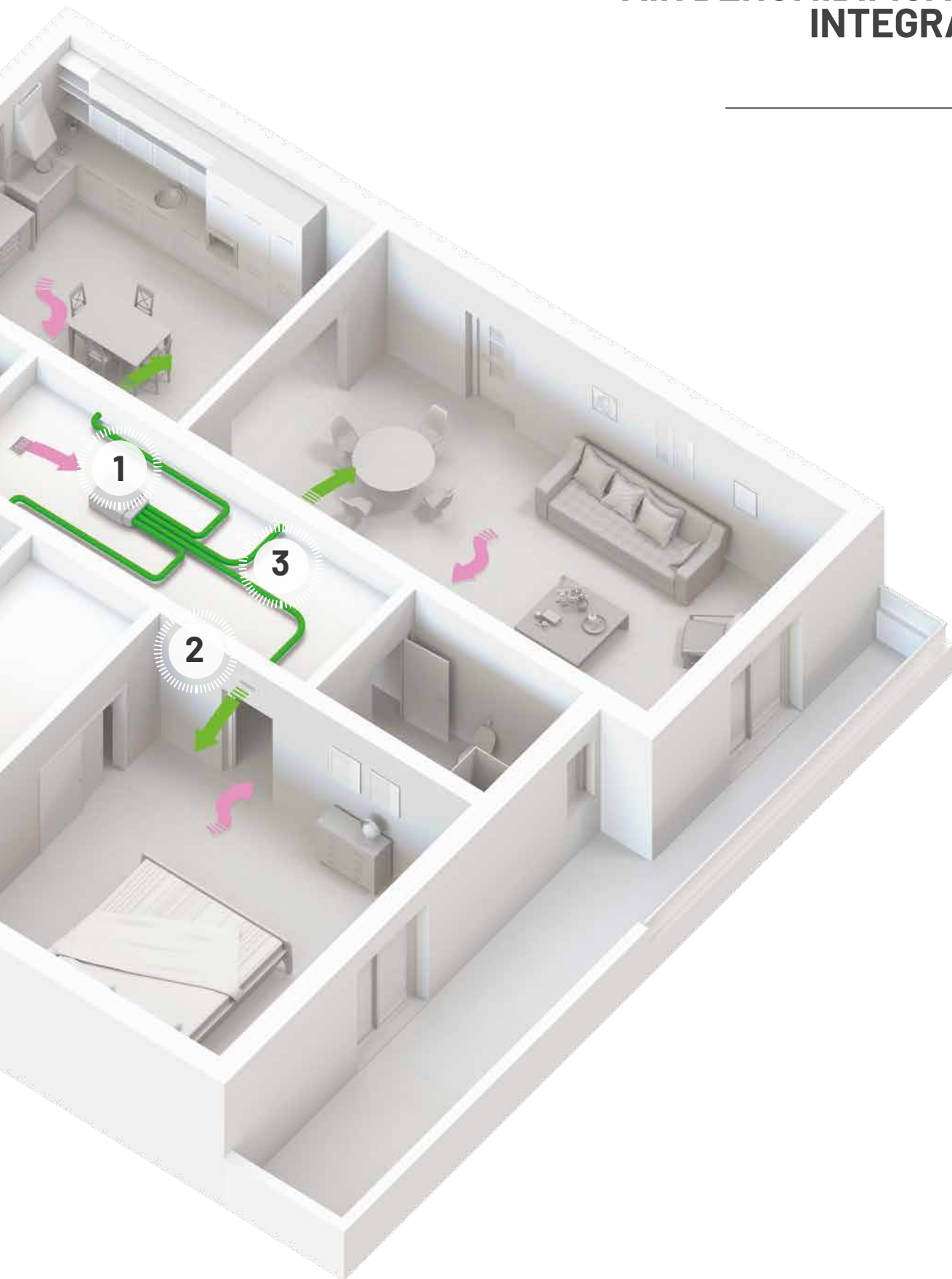

1 - Ventilation units



2 - Plenums for machines and manifolds



3 - Grids and external terminals



4 - Plenums for room openings and grids



5 - Ducts, fittings, accessories



HEAT RECUPERATORS WITH DEHUMIDIFICATION / THERMODYNAMIC INTEGRATION



1 - Ventilation units



2 - Plenums for machines and manifolds



3 - Grids and external terminals



4 - Plenums for room openings and grids



5 - Ducts, fittings, accessories



HEAT RECUPERATORS WITH DEHUMIDIFICATION AND HYDRONIC INTEGRATION

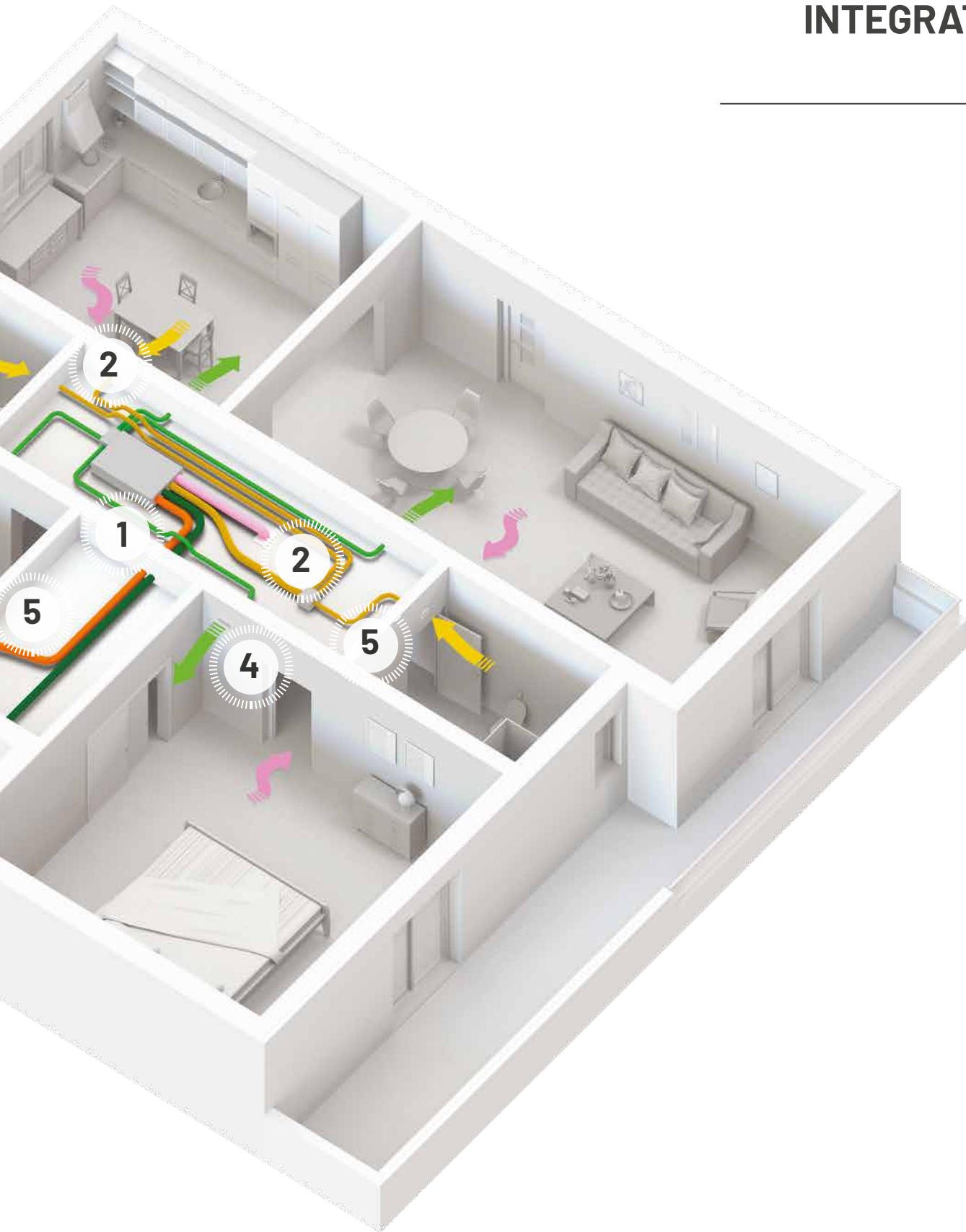

**GREATER ENERGY EFFICIENCY AND ECO-SUSTAINABILITY:
THE INNOVATION BY GIACOMINI HAS NO BOUNDARIES.**



The new air treatment units by Giacomini combine top-notch technical performance to an eco-friendly core: the cooling fluid used in the cooling circuit is R290 propane, featuring an outstanding thermodynamic performance and a natural alternative to traditional cooling gases with high contents of GWP. The Global Warming Potential parameter identifies

the greenhouse-effect global warming potential caused by a specific gas in the atmosphere. Taking as reference value carbon dioxide CO₂, equal to 1, the choice of gas R290 was determined by its GWP=3, a value extremely lower than GWP=1300 of gas R134a used so far.

The technical development based on the load of R290 refrigerant has enhanced "key" components, such as the compressor, which increases efficiency by 30% compared to the previous model.



Radiant Systems

Catalog - Price List
 05/2019 ITALY

ER0008 JUN2019

**Air Treatment
and Residential
HRV**

Technical solutions
for integration
into radiant systems



HPM

High efficiency air/water monoblock heat pump, hot/cold reversible. With DC inverter compressor, DC brushless fans and DC inverter circulator. Anti-

freezing kit included. Voltage: single-phase or three-phase (based on machine power).



ANTI-FREEZING KIT INCLUDED

HPMY006: COP 4,47 - EER 4,06
 HPMY008: COP 4,33 - EER 3,91
 HPMY010: COP 4,43 - EER 4,43
 HPMY012: COP 4,19 - EER 4,49
 HPMY014: COP 4,30 - EER 4,70
 HPMY016: COP 4,41 - EER 4,90
 Cooling (EER) and heating (COP) nominal capacities are set according to Standard EN 14511.

i INFORMATION

For more details on supply terms and conditions, contact our Sales Managers.

First startup is mandatory (by Authorized Technical Assistance Operators): net price € 100,00.

Operations to be carried out by the installer

- Complete filling of hydraulic system
- Wirings between HPM heat pump and accessories installed

Operations to be carried out by the authorized technical assistance operators

- State-of-the-art inspection of HPM hydraulic

circuits according to installation technical specifications

- State-of-the-art inspection of wirings, safety alarm control, correct water flow
- Setting up of operational parameters based on project requirements
- Drawing up of "first start up" form and provision of useful operational data to the client

Certifications

Eurovent

DIMENSIONS AND WEIGHTS

Product code	L - mm	H - mm	D - mm	Net weight - kg	Working weight - kg
HPMY006	925	769	380	63,4	67
HPMY008					67,5
HPMY010	1047	898	465	95,5	97
HPMY012					
HPMY014	1060	1405	455	115,5	119
HPMY016				126,3	



ENERGY EFFICIENCY ERP

Product code	Heating energy efficiency class	
	55 °C	35 °C
HPMY006	A+	A++
HPMY008	A+	A++
HPMY010	A+	A++
HPMY012	A+	A++
HPMY014	A+	A++
HPMY016	A++	A++

HPC

High efficiency air/water monoblock heat pump, hot/cold reversible. Including an integrated hydronic module for 250-l technical stock for instantaneous production of domestic hot water.

With DC inverter compressor, DC brushless fans and DC inverter circulator. Anti-freezing kit included. Voltage: single-phase or three-phase (based on machine power).



ANTI-FREEZING KIT INCLUDED

HPCY006: COP 4,47 - EER 4,06
 HPCY008: COP 4,33 - EER 3,91
 HPCY010: COP 4,43 - EER 4,43
 HPCY012: COP 4,19 - EER 4,49
 HPCY014: COP 4,30 - EER 4,70
 HPCY016: COP 4,41 - EER 4,90

Cooling(EER)and heating(COP)
 nominal capacities are set according
 to Standard EN 14511.

❶ INFORMATION

For more details on supply terms and conditions, contact our Sales Managers.

First startup is mandatory (by Authorized Technical Assistance Operators): net price € 135,00.

Operations to be carried out by the installer

- Complete connection of cooling pipes between external unit and integrated module
- Seal testing of cooling pipes with nitrogen pressurization and vacuum
- Complete filling of hydraulic system
- Wirings between HPC heat pump and accessories installed

Operations to be carried out by the authorized

technical assistance operators

- Vacuum testing of cooling pipes and opening of R410A-gas pipe cocks
- State-of-the-art inspection of HPC hydraulic circuits according to installation technical specifications
- State-of-the-art inspection of wirings, safety alarm control, correct water flow
- Setting up of operational parameters based on project requirements.
- Drawing up of "First start up" form and provision of useful operational data to the client.

Certifications

Eurovent

DIMENSIONS AND WEIGHTS - HYDRONIC MODULE

Product code	L - mm	H - mm	D - mm	Net weight - kg	Working weight - kg
HPCY006	595	1830	705	189	449
HPCY008					
HPCY010				190	450
HPCY012					
HPCY014				192	452
HPCY016					

DIMENSIONS AND WEIGHTS - EXTERNAL UNIT

L - mm	H - mm	D - mm	Working weight - kg
925	769	380	62
1047	898	465	83,5
1060	1405	455	112,2
			123

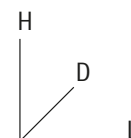

ENERGY EFFICIENCY ERP

Product code	Heating energy efficiency class		Domestic hot water energy efficiency class	
	55 °C			Profile
HPCY006	A+		A+	L
HPCY008	A+		A+	L
HPCY010	A+		A+	L
HPCY012	A+		A+	L
HPCY014	A+		A+	L
HPCY016	A++		A+	L



HPCS

High efficiency air/water monoblock heat pump, hot/cold reversible. With integrated hydronic module of technical stock for instantaneous production of domestic hot water and possible inertial puffer. Integration system and control of

solar circuit included. With DC inverter compressor, DC brushless fans and DC inverter circulator. Anti-freezing kit included. Voltage: single-phase or three-phase (based on machine power).



ANTI-FREEZING KIT INCLUDED

HPCSY006, HPCSY106: COP 4,47 - EER 4,06
 HPCSY008, HPCSY108: COP 4,33 - EER 3,91
 HPCSY010, HPCSY110: COP 4,43 - EER 4,43
 HPCSY012, HPCSY112: COP 4,19 - EER 4,49
 HPCSY014, HPCSY114: COP 4,30 - EER 4,70
 HPCSY016, HPCSY116: COP 4,41 - EER 4,90

Cooling (EER) and heating (COP) nominal capacities are set according to Standard EN 14511.

Integrated hydronic module available in 2 versions:
 - with 250-l technical stock for instantaneous production of domestic hot water;
 - with 190-l technical stock for instantaneous production of domestic hot water and 40-l inertial puffer;

ⓘ INFORMATION

For more details on supply terms and conditions, contact our Sales Managers.

First startup is mandatory (by Authorized Technical Assistance Operators): net price € 135,00.

Operations to be carried out by the installer

- Complete connection of cooling pipes between external unit and integrated module
- Seal testing of cooling pipes with nitrogen pressurization and vacuum execution
- Complete filling of hydraulic system
- Wirings between HPCS heat pump and accessories installed

Operations to be carried out by the authorized technical assistance operators

- Vacuum testing of cooling pipes and opening of R410A-gas pipe cocks
- State-of-the-art inspection of HPCS hydraulic circuits according to installation technical specifications
- State-of-the-art inspection of wirings, safety alarm control, correct water flow
- Setting up of operational parameters based on project requirements
- Drawing up of "First start up" form and provision of useful operational data to the client

Certifications

Eurovent

DIMENSIONS AND WEIGHTS - HYDRONIC MODULE

Product code	L - mm	H - mm	D - mm	Net weight - kg	Working weight - kg
HPCSY006	595	1830	705	204	466
HPCSY008				205	467
HPCSY010				207	469
HPCSY012				217	479
HPCSY014				218	480
HPCSY016				220	482
HPCSY106					
HPCSY108					
HPCSY110					
HPCSY112					
HPCSY114					
HPCSY116					

DIMENSIONS AND WEIGHTS - EXTERNAL UNIT

L - mm	H - mm	D - mm	Working weight - kg
925	769	380	62
1047	898	465	83,5
1060	1405	455	112,2 123
925	769	380	62
1047	898	465	83,5
1060	1405	455	112,2 123

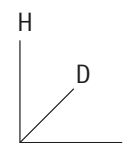

ENERGY EFFICIENCY ERP

Product code	Heating energy efficiency class		Domestic hot water energy efficiency class	
	55 °C		Profile	
HPCSY006	A+	A+	L	
HPCSY008	A+	A+		
HPCSY010	A+	A+	L	
HPCSY012	A+	A+		
HPCSY014	A+	A+	L	
HPCSY016	A++	A+		
HPCSY106	A+	A+	L	
HPCSY108	A+	A+		
HPCSY110	A+	A+	L	
HPCSY112	A+	A+		
HPCSY114	A+	A+	L	
HPCSY116	A++	A+		





ACCESSORIES AND OTHER COMPONENTS

A passion for excellence. Painstaking attention to detail. The highest quality in every single component. Only the best for each item or accessory.





K369A WALL EDGING STRIP

DESCRIPTION

K369A is a polyethylene edging strip for installation along walls to absorb any settling movement of the radiant floor.

The 8 mm thick strip is provided in 50 m rolls with two specific heights: 150 mm and 250 mm. The 250 mm version is particularly recommended for industrial installations where screeds generally

present larger dimensions.

The strip has an adhesive side for easy and rapid application on walls.

For installation complying with standard UNI EN 1264-4:2009, refer to the corresponding section of chapter 8.



SCREED SECTION

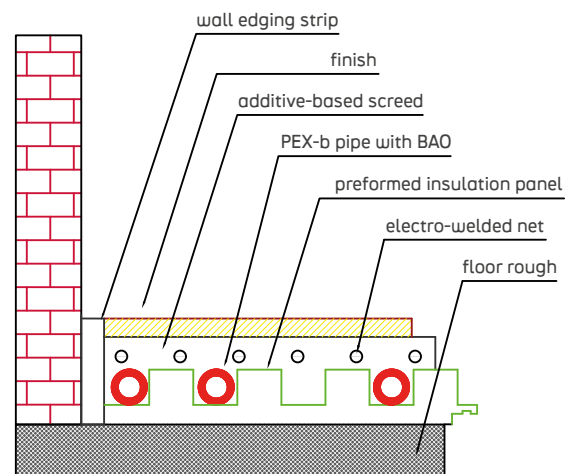

K369D EXPANSION JOINT STRIP AND R872D, R872U TRACK

DESCRIPTION

The K369D strip is a polyethylene band used as expansion joint to prevent screed movements, caused by thermal expansion or shrinking, from damaging the lithoid surface finish. The 8 mm strip is provided in 50 m rolls 150 mm high for installation on site. For installation complying with standard UNI EN 1264-4:2009, refer to the related section of chapter 8. R872D plastic tracks are used to apply the K369D strips which work as expansion joints. They are provided in 2 m rods. The tracks have an

adhesive strip at the base for correct installation on the support surface of the radiant screed; their central section is elastic so that it can adapt to the thickness of the expansion joint.

Universal dilation and fractioning joint for radiant screeds.

Reversible application: lay on adhesive base for dilation joints; fit between the protrusions of the insulation panel for fractioning joints. Length 2 m.

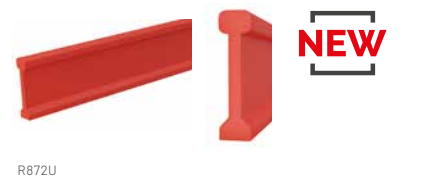
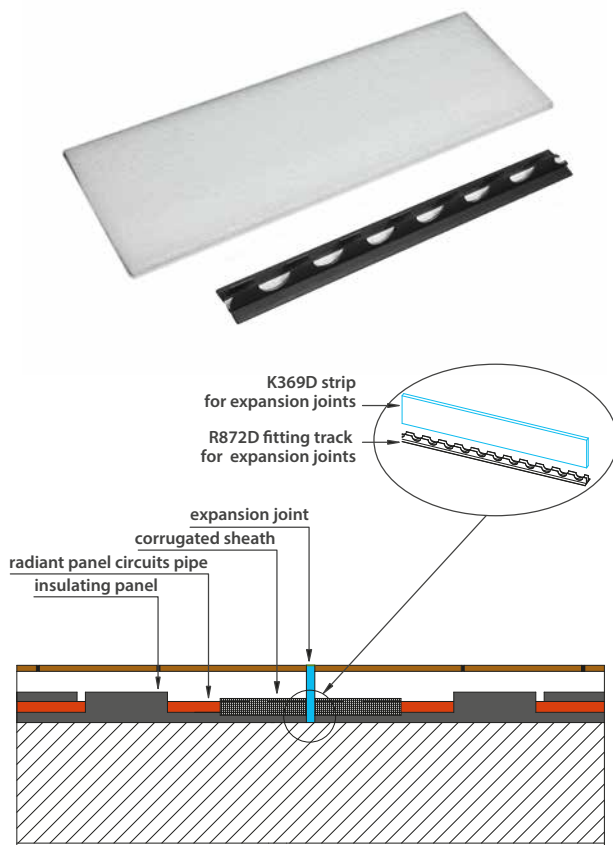

R872U

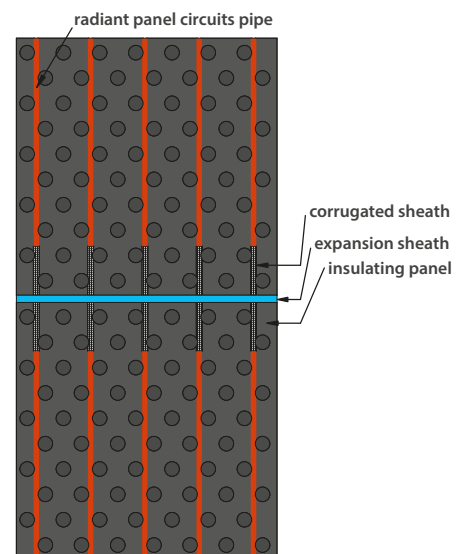

R146I-R146IM HYDRAULIC SEPARATOR

DESCRIPTION

Generally, the boiler room circulator is not able to meet the hydraulic requirement of thermal systems. That is why two or multiple secondary circulators sized according to the specifications of the various usage points (temperature, hydraulic head and flow rate) must be installed. The operational conditions of the interacting pumps, which can create anomalous flows and circuit heads, can be then verified. The hydraulic separator – or compensator – is a device that de-couples the primary circulator's flow rate (production) from the secondary's (system): it makes the connected



circuits hydraulically independent by creating a zone with reduced loss of pressure. The flow rate passing through the respective circuits depends exclusively on the flow rate characteristics of the pump, preventing mutual interferences caused by their series coupling. Use of an hydraulic separator provides a production circuit with constant flow rate and a distribution circuit with a variable one, that is working conditions typical of modern air conditioning systems. Also available in the magnetic version to further safeguard the operation and energy performance of both the radiant system and the generator.

👍 WHY CHOOSING IT?

- No interferences between the circulators
- Enhanced system efficiency
- Insulation kit included
- Version with magnet

OPERATIONAL PRINCIPLE

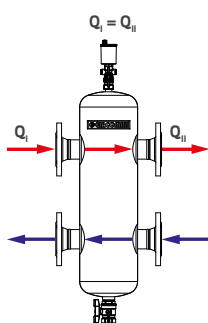

The two fluids are not mixed when the primary circuit flow rate is the same circulating in the secondary.

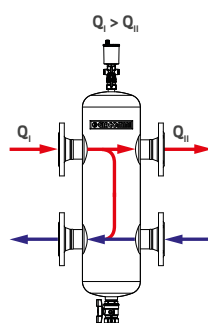

If the primary circuit flow rate is greater than the secondary, part of the flow rate entering the separator from the primary circuit will be bypassed by the separator and then flow back to the boiler.

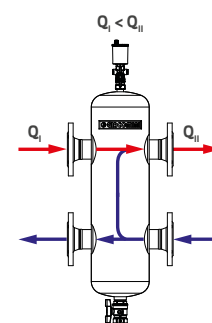

If the secondary circuit flow rate is greater than the primary, part of the flow rate entering the separator from the secondary circuit will not return to the boiler, but it will be bypassed by the separator and flow back into the system.

R146M DIRT SEPARATOR

DESCRIPTION

R146M dirt separator is a device that separates and removes the debris inside hydraulic circuits of modern air conditioning systems. The heat transfer fluid enters the dirt separator and slows down when colliding with a special metal mesh (element A, fig. 7.1) which filters solid impurities. Ferrous debris are trapped by the attraction force generated by the non-removable magnet resistant to high temperatures (element B, fig. 7.1).

The separator must be installed on the return circuit to protect the boiler from the debris inside the duct. The filter can be easily cleaned by opening the drain cock and removing the magnet from the top of the housing.

R146D standard threaded dirt separators can be converted into magnetic dirt separators by installing the P146M kit (fig. 7.2).



👍 WHY CHOOSING IT?

- It protects the system from debris, ferrous impurities included
- It extends the system operational life
- Extremely easy maintenance and cleaning of the filters and magnet without disassembling or turning off the system

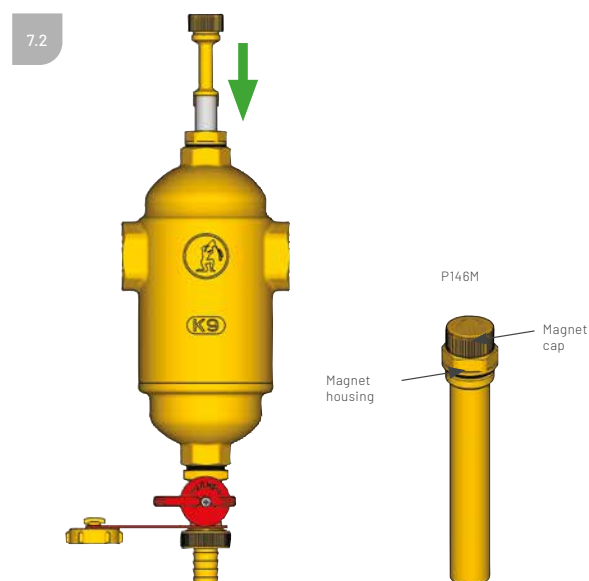
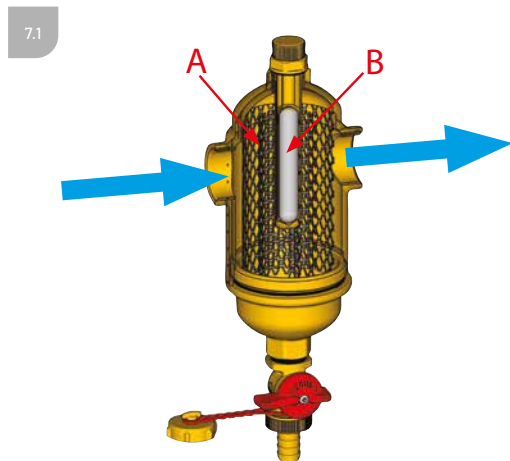

K375 PROTECTIVE ADDITIVE

European standard UNI EN 1264, which includes all regulations for water-fed radiant systems, provides for both anti-oxygen barrier pipes and use of chemical corrosion inhibitors for metal components – especially ferrous parts – included in the system. The application of both measures represents the most effective protection against corrosion of the system metal components. Oxygen may penetrate the system water also through the pump joints or automatic air vent valves and make the anti-oxygen barrier useless. The K375 inhibitor additive for radiant systems with synthetic pipes must be periodically integrated according to the dosage specified by the specific technical sheet.



K376 CONCRETE FLUIDIFYING ADDITIVE

The K376 additive is a mixture of specific products to enhance concrete mixing and blending: it is used both for installation of radiant floors and preparation of concrete with high fluidity characteristics.

It does not contain components harmful for concrete, metals or plastic pipes. It must be added upon mixing according to the dosage specified by the specific technical sheet.

The main benefits of K376 are:

- reduced laying times
- no vibration required for additive-based concrete
- cuts down the required quantities of water up to 25%
- reduction of aging cycles
- reduced shrinking thanks to the enhanced water/concrete ratio
- enhanced concrete impermeability.



K393 ELECTRO-WELDED NET

The electro-welded net is the most popular reinforcement system for concrete floors, basically for its competitive installation cost. It does not increase the screed resistance to flexibility, but limits instead the crevices in the concrete caused by hygrometric shrinking.

The K393 galvanized electro-welded net by Giacomini is made with a \varnothing 1,6 mm thread consisting of 50 mm square meshes.

For installation on top of the radiant system after laying the pipes so as to fit it in the screed section at a suitable height to prevent cutting it when creating the expansion joints.

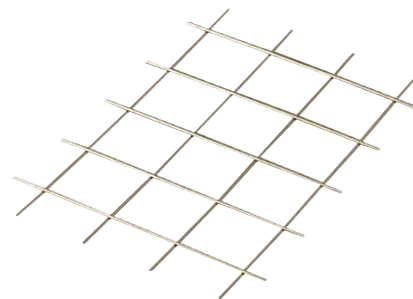

K389 AND K389W PIPE INSTALLATION TRACKS

The K389 and K389W tracks enable to rapidly and safely install the radiant system circuits both on large surfaces with smooth insulation panels and Klima Wall systems thanks to the special profile of the pipe housings.

The K389W pipe installation track includes a firm connection system for the single elements to create the support required for the radiant circuits on the entire surface.

Fitting of the tracks to the insulation panel is ensured by clips anchored to dedicated housings.

Made in plastic, there are multiple versions available based on pipe diameter and laying pitch.

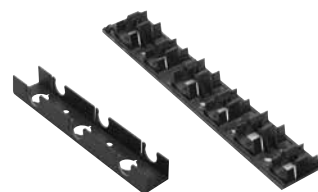

PIPE-FITTING CLIPS AND CLIP TACKER

The R983 clips are extremely useful to fit the plastic pipes on the insulation panels when necessary. Available in multiple versions according to their use: for manual application on panels of different thicknesses and for application with the special clip tacker (generally on flat panels). Klima Dry radiant systems require the special K809 clips.



R549P BEND SUPPORT

Bend supports are a professional solution to neatly install manifold inlet and outlet pipes.

Easy to install, they prevent damaging the pipe with narrow bends for connection to the manifold.

They are made in high-temperature resistant plastic.



SOUND ABSORPTION ACCESSORIES

K369A

Polyethylene wall edge strip for radiant floor systems. Featuring an adhesive side and a protection edge on the other. Roll length 50 m. Temperature range -20÷80 °C.



K369D

Polyethylene strip for dilation joints. Roll length 50 m. Temperature range -20÷80 °C.



R872D

Fitting track for dilation joints. Adhesive strip included.
Track length 2 m.

**K376**

Concrete fluidifying additive for radiant panel floor foundations.

**K369L**

Cork edge strip for radiant floor systems. Roll length 25 m.

**K369PH**

Edge strip and coating accessories for structural elements (angles, edges, door frames) for radiant floor systems of enhanced sound absorbing capacity. Made with 6-mm elasticized polyethylene foam. Adhesive for easy installation and protection layer for layers beneath the floating screed. Edging strip provided in rolls with precuts. Temperature range -20+80 °C.

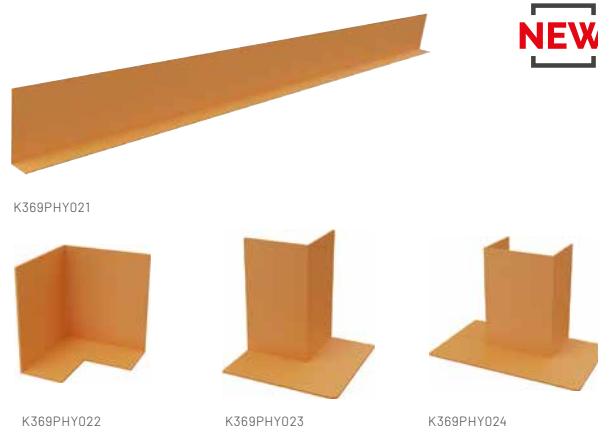
**R872U**

Universal dilation and fractioning joint for radiant screeds.
Reversible application: lay on adhesive base for dilation joints; fit between the protrusions of the insulation panel for fractioning joints. Length 2 m



K380

CLEAN is a neutral rapid and efficient cleaner for heating systems and to flush radiant panel systems. Used in new installations, it removes machining debris, oils, grease, corrosive dross and other debris before start up.

**K375**

PROTECT-UNIVERSAL, special anti-corrosive and anti-scaling fluid, fully organic and suitable for high and low temperature systems, radiant panels and hot/cold water circuits. It prevents the formation of undesired algae, slush and bacteria. The product is thermostable, biodegradable, non-toxic and does not damage drains.

**K809**

Pipe-fitting clips for dry radiant floor systems (K809Y001) or to connect preformed panels (K809Y500).

**R984**

Waterproof layer to protect radiant floor systems from water vapor. Grid pattern for simplified laying of the pipes. Provided in 1,25x100 m rolls.

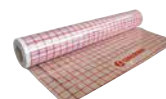
**R983N**

Galvanized metal electro-welded net. 50x50 mm mesh. Wire diameter 1,6 mm.

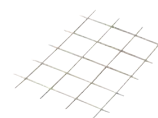
**K393**

Plastic plug for fitting of R979S self-adhesive panels and panels with insulation



TIME TO BIM

+800 PRODUCTS BY GIACOMINI FOR BIM NOW AVAILABLE AT MAGICLOUD.COM

Giacomini provides planners and installers 3D drawings of its products for BIM applications. Acronym of **Building Information Modeling**, BIM helps planners to easily communicate and exploit at best the IT tools for system sizing and positioning, among which modeling and bills of quantities.

+800 product codes in 3D by Giacomini are already available at magiccloud.com and compatible with Magicad (.qpd), Autocad (.dxf) e Revit (.rfa). BIM helps planners easily assemble their projects with Giacomini components.

Magiccloud provides planners with drawings and calculation functions for: heating, cooling, ventilation, air conditioning, water distribution systems - sewerage systems and watering systems - in addition to special functions such as energy-saving calculations.

The BIM approach offers great benefits such as enhanced efficiency and productivity, fewer errors, time saving, information sharing and better control of the project.



Log in at <http://www.magiccloud.com> and start your project right away!

Products compatible with	File type
MAGICAD	.QPD
AUTOCAD	.DXF
REVIT	.RFA





REGULATORY COMPLIANCE INSTALLATION

STANDARD UNI EN 1264

The UNI EN 1264 European technical standard includes all regulations for application with water-fed radiant air conditioning systems integrated in structures of residential buildings, offices and other buildings which use corresponds or is similar to residential.

Below is a summary of its parts:

- **UNI EN 1264-1:2011** It defines the field of application, the terms and the symbols used in the subsequent parts of the standard.
- **UNI EN 1264-2:2013** It is the standard part specifying the surrounding conditions and methods to determine the thermal power of radiant floor systems fed with hot water, based on the difference between the heating average temperature and the room temperature. The thermal power is determined based on calculation and testing methods. The manufacturer can state the power of its radiant system based on the indications provided for by the UNI EN 1264-2 standard. As for the dispersed power, the performance varies according to the thermal resistance of the insulation panel installed.
- **UNI EN 1264-3:2009** It is the standard part referring to sizing of radiant systems based on the thermal loads to be balanced. It provides that the maximum specific power provided by radiant heating surfaces derives from limits set for the surface temperature values. Sizing of the floor system provides: installation center distance, feeding temperature and flow rates circulating in the system single loops. If the system also provides cooling, the UNI EN 1264-3 standard sets how to apply the UNI EN 1264-5 contents to determine summer regime outputs.
- **UNI EN 1264-4:2009** This standard part refers to installation of radiant systems embedded in the structure and defines the minimum requirements of the materials used and the provisions that must be complied with for a correct realization. Reference will follow when specifying the various installation steps of the system.
- **UNI EN 1264-5:2009** This is the standard part providing indications to evaluate the thermal power of heating and/or cooling radiant floors and walls in addition to the thermal power of radiant cooling floors. The recalculation method described by the standard enables to obtain the outputs for the other surfaces (ceilings and walls) and for cooling applications (floors, ceilings and walls) based on calculations and test results related to the heating floor (part 2 of the standard) and applying specific coefficients of thermal exchange.

Various calculation software are available to easily plan and size radiant floor systems based on the standard parts described above.

GiacoKlima©Tool is the courtesy calculation and budget program offered by Giacomini to its clients.

In order to guarantee the best performance of the radiant floor and satisfy the user, the installer



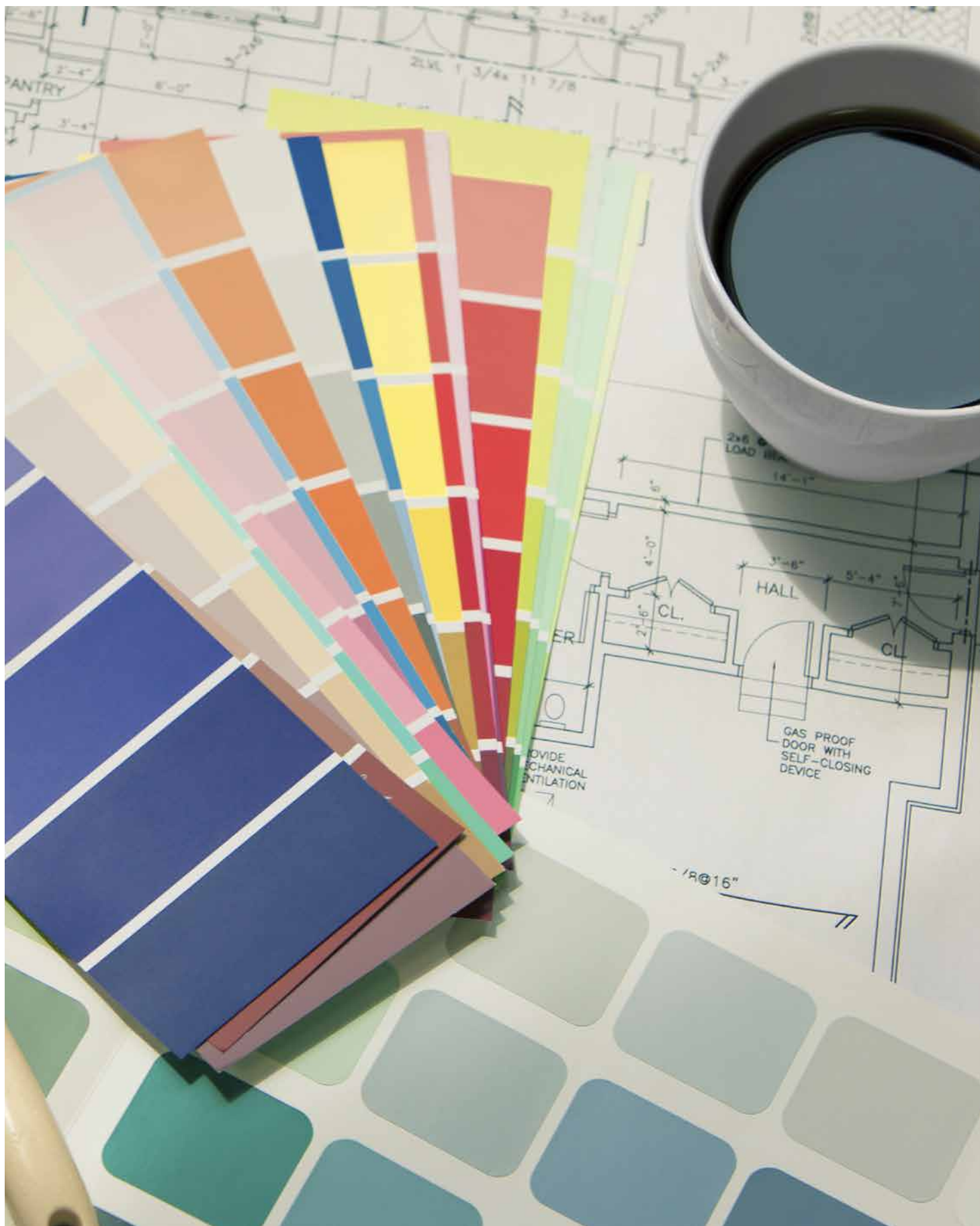

must strictly comply with the various installation steps defined by UNI EN 1264-4:2009 described below, carry out a correct planning and use top quality components. This part applies only to

heating/cooling radiant system components and not to other elements of the floor, ceiling and wall structure.

PRE-EXISTING CONDITIONS FOR INSTALLATION OF RADIANT FLOORS

The standard defines the conditions required for installation of radiant floors: the building openings must be sealed by installing external doors, windows and shutters, by applying the internal door frames and by the existing plasters. In addition, all system pipes (plumbing, electric, sanitary fixtures, etc.) must already be installed and covered so as to obtain the support base required to install the insulation layer.

Two methods can be adopted to install the systems:

- installation of the systems on the unfinished slab and then smoothing with lightweight

material. The insulation panel, the pipes and the electro-welded net will be laid on top of this support, then the radiant screed will be installed and completed with the desired surface finish

- the second method is frequently used when there isn't enough space for traditional installations; however, the standard of reference does not provide any indication for it. A slab portion must be kept free along the wall edges where the service ducts and pipes will be laid in place of the insulation panel (fig. 8.1).

8.1

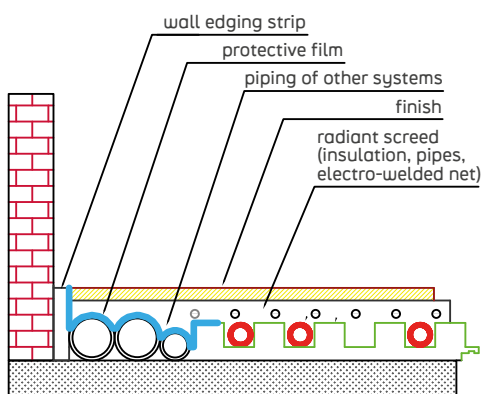

Section of the screed with other systems



MANIFOLD INSTALLATION

The distribution manifold is the first component of the system to be installed and must be positioned so as to reduce the length of the adduction pipe to the minimum. This will make temperature control in the various rooms easier as the adduction piping will be more contained.

It is generally installed in special cabinets or niches at a height which makes pipe connection, filling operations and air venting of the circuits easier.

It must be equipped with two delivery and return

shut-off valves on the risers and a calibration device for each circuit. Closing and calibration of the circuit must be independent.

The system must include safety devices working also in case of power failure to prevent heating water from entering the circuits at an excessive temperature. Humidity sensors are instead required for cooling so as not to reach the dew temperature.

WALL EDGE STRIP INSTALLATION

The wall edge strip must be installed along every wall bordering the floor-heated room and every structural component inserted in the screed (pillars, steps, internal door frames, etc.).

This insulation strip must connect the support base vertically to the finished floor surface and its characteristics must be such to enable the screed to move by at least 5 mm. It must be fixed

to the wall to prevent any movement while laying the rough concrete. The edge strip and adjoining insulation protection layer must be installed so as to prevent the fluid screed from penetrating along the perimeter under the insulation. The upper part of the edge strip extending above the floor has to be cut after completing the surface finish (before positioning skirting boards).



INSULATION PANEL INSTALLATION

The insulation of the radiant floor system must have a minimum thermal resistance higher or equal to the value provided for by the standard (see fig. 1.3, chapter 1). It must be lined on top by a protective layer made by a polyethylene sheet thick at least 0.15 mm (already provided for all models by Giacomini) or an equivalent material.

The insulation panels must be flush with the edge strip, making sure to lift the polyethylene clear film on top to guarantee an uninterrupted protection layer. The panels must then be gently placed on the ground staggering the subsequent rows.

Preformed insulation panels can be easily and quickly installed thanks to the special couplings (extending strips of thermoformed material or

grooves) on the two orthogonal sides which neatly fit the panels one to the other: the final result is a state-of-the-art support surface for hydraulic circuits with no thermal bridges.

The diagram of fig. 8.2 shows how to rapidly install the panels. The two extending strips of sheet n. 1 can be removed by using a cutter and the sheet is then placed in the corner more suitable to start laying.

Sheet n. 2 is trimmed only on its longer side. The strip of the shorter side will enable to fit it to sheet n.1. This step is repeated for all sheets of the first row. Each panel of the subsequent rows will be coupled to the adjoining row, staggering the panels according to the initial pattern.

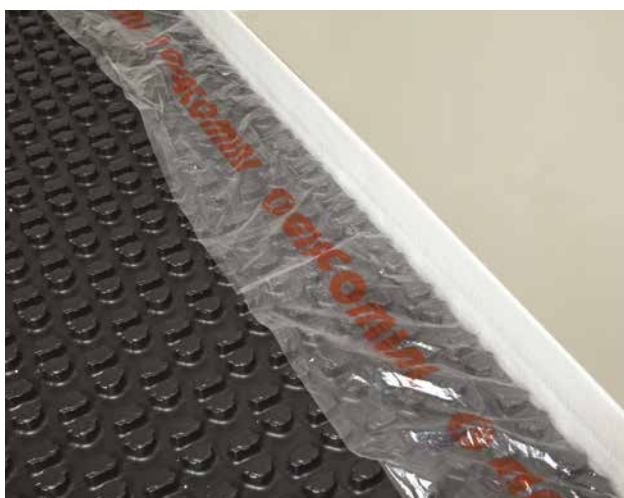

8.2

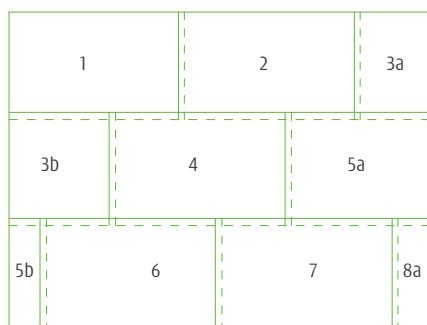

SCREED JOINTS

The sudden thermal changes affecting the radiant screed may cause imperceptible movements on the screed itself. Expansion joints may be required to prevent this effect from damaging the lithoid surface finish (such as marble and ceramic) in time. The position of the expansion joints must be established during planning as the delivery pipe and the return pipe can each cross each circuit only once. The joint positions and quantities must be such to border areas not exceeding 40 m² and with an 8-m max length. These dimensions can be exceeded with rectangular areas if one of the dimensions is not larger than twice the other. Irregular shapes are not allowed.

Expansion joints must be provided near every

door and structural joints must be reproduced also in the expansion joints.

The two pipes of each circuit crossing the expansion joints must be protected with a flexible insulating material for at least 0,3 m.

The market currently offers screeds with enhanced anti-shrinking characteristics, thanks to the ongoing studies carried out to improve the performance of radiant systems: they enable to obtain, in total safety for the floor, larger surfaces between the joints up to preventing their application. When choosing this type of screeds, the installer must strictly follow the instructions provided for by the product technical sheets.



PIPE INSTALLATION

Pipes must be protected from external damages and direct solar irradiation when handled and stocked. They must be installed complying with the project pitches and lengths to guarantee the desired output and operation.

The system circuits can have a "spiral" or "coil" layout: the first is more recommended as it offers a more even distribution of the surface temperature; the coil layout instead leads to a gradual reduction of the surface temperature from the manifold delivery point to the return point.

Every possible cause of damage to the pipes must be prevented (for example, installation near flues,

fireplaces with low-set furnaces, etc.). The bending radius must comply with the manufacturer's specifications. A bending radius lower than the specified minimum value requires bend supports to prevent pipe crushing caused by too narrow bends that reduce the passage section.

The pipe must be connected with anchoring systems that may to guarantee a max shift of 5 mm of height and 10 mm along the plane from the installation position.

The R979 and R979N panels are equipped with convenient fins on the protrusion tops which ease installation by holding the pipe in place without

using fitting clips.

The distance between the circuit pipes is very reduced near the manifold so the heat supply is very high: it is therefore advisable to insulate the delivery pipes connected to the manifold

to separate them properly (about 1 m from the manifold).

We recommend to install the special bend supports to ease installation of the manifold inlet and outlet pipes.

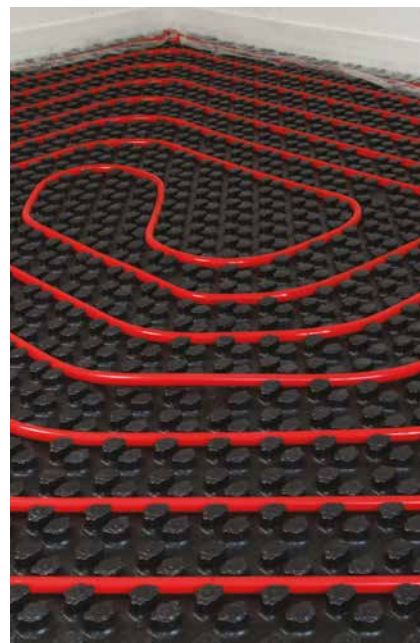
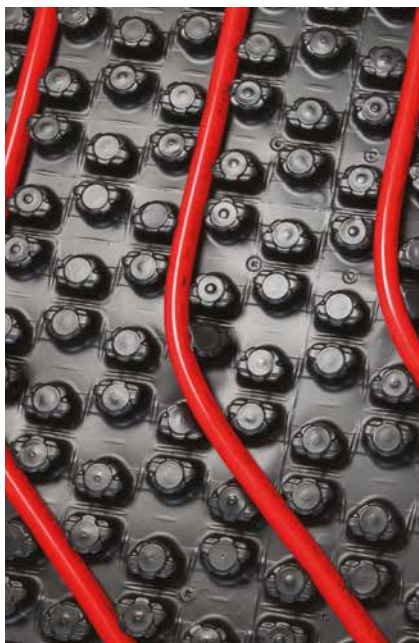

ELECTRO-WELDED NET INSTALLATION

Once completed the installation of the circuits, it is advisable to lay an electro-welded net with large meshes on the entire surface covered by the insulation panels. The standards do not expressly provide for its use, yet it is always recommended to minimize crevices caused by drying of the screed. The use of an electro-welded net with properly sized meshes and thicknesses must be evaluated when realizing radiant floors for

industrial structures and whenever there are particularly heavy and/or concentrated loads.

Finally, it must be pointed out that when using specific fiber-reinforced premixed screeds (with amorphous stainless metal fibers) the reinforcement net is not required (**however the manufacturer's datasheet specifications must be complied with**).

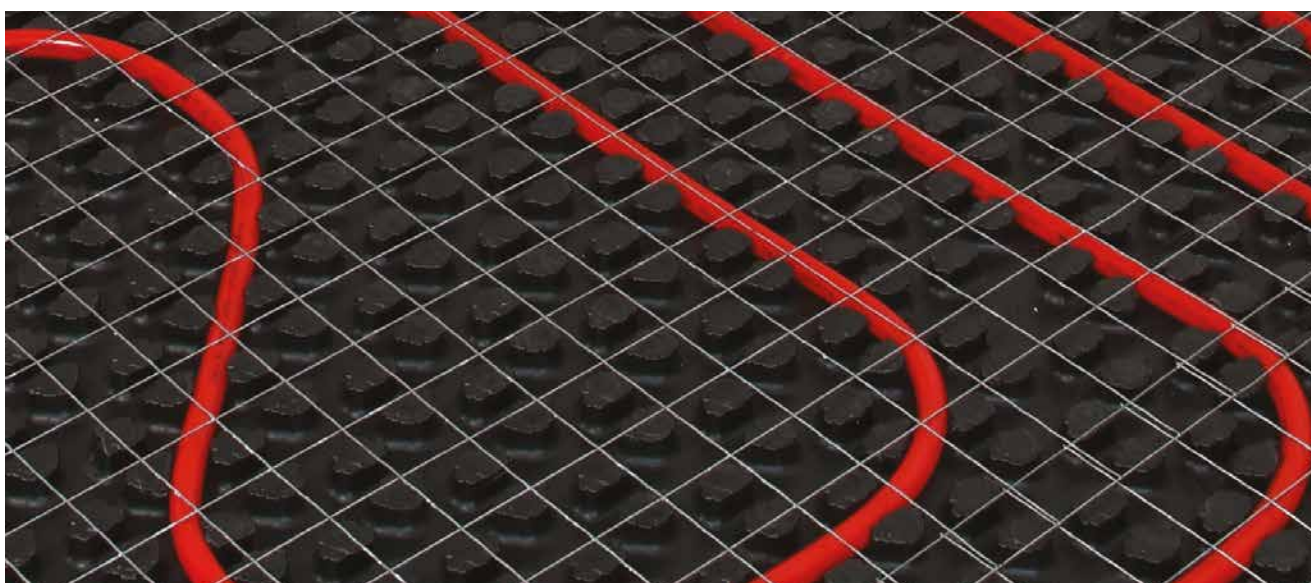

FILLING AND TESTING THE SYSTEM

Before laying the concrete screed, a pressure not lower than 4 bar and not exceeding 6 bar must be applied to the system loops to make sure there are no leakages.

This test can be performed with water or compressed air and the absence of leaks must be registered on a test chart indicating the test pressure. In case of freezing risks, precautionary measures must be adopted such as adding glycol to the filling water. Glycol must be removed and the pipes rinsed when the system is set on regular activation.

When filling the system with water, air must be

removed manually by filling the pipes according to the instructions below:

- close all panel return circuits
- supply the delivery manifolds
- open the return manifold circuits one at a time as described below:
 - open the handwheel of the valve integrated in the return manifold, keeping all the other valves closed
 - purge the drain cock and keep purging till there is no more air mixed to the water
 - close the valve of the full circuit and open the next one purging it as described above

SCREED LAYING

With regard to the screed, standard UNI EN 1264-4 recommends a thickness not lower than the values provided for by the regulations specifying its load capacity and flexibility resistance class. With sand, concrete and additive-based screeds **the installer must comply with the product datasheet**. This applies also for premixed screeds provided in bags ready for use.

Before laying, make sure all external openings are perfectly sealed to prevent air from penetrating the room. The screed is laid right after installing and pressurizing the system, trying not to cover the circuits completely, starting from the edges

and continuing towards the center. The screed installer must avoid damaging the radiant floor components.

The screed must be laid and left aging for at least 3 days at a minimum temperature of 5 °C. Prevent the screed from drying too quickly for at least 3 days; a longer period may be necessary based on the type of material used.

The screed must be laid respecting the expansion joints where required. Any hole in the floor must be made before installing the panel.

Vertical pipes which may cross the slab must be separated from it using a proper duct.



SYSTEM START UP

According to the provisions set forth by standard UNI EN 1264-4, start up of the system – the initial heating – must be performed at least 21 days after laying the concrete screed (unless different specifications are provided for by the manufacturers of specific screeds). Initially the

supply temperature must be approx. 20÷25 °C for at least 3 days, then the system can be set on the project temperature to be maintained for at least 4 additional days.

The installer must report in writing the initial start up.

SURFACE FINISH LAYING

The surface finish can be laid after starting up the system. The finish installer must make sure that the

coating chosen can be applied and that the materials used are compatible with radiant floors.

INSTALLATION OF R979S SPIDER PANELS

Spider panels require differentiated installation steps that vary from the traditional methods based on the model.

R979SY001-005

The floor rough must be carefully cleaned from any dirt/dust as this model includes an adhesive support. Once the protective sheet has been removed from the bottom of the grid, glue the panel to the rough or existing floor, overlapping the side hooks for proper fitting (R983Y040 screw anchors may be required to ensure adherence to the existing flooring when the surface is not perfectly smooth and clean).



R979SY011

Connect the panel to the smooth insulation panels already installed using the pegs and placing the panels one next to the other for proper fitting. Use clips R983Y001 or R983Y003 to fit the pipe and panel to the insulation if necessary.



R979SY021-025

Place the panels on the floor rough or existing floor, overlapping the side hooks for proper fitting of the panels. Use R983Y041 screw anchors to fit the pipe and panel.

Lay the screed chosen with the system already pressurized at 6 bar at least, strictly complying with the manufacturer's instructions:

- self-leveling screed (R979SY001-005 and R979SY021-025 panels only)
- anhydrite-based screeds (for all three versions)
- traditional sand-concrete screeds (for all three versions)

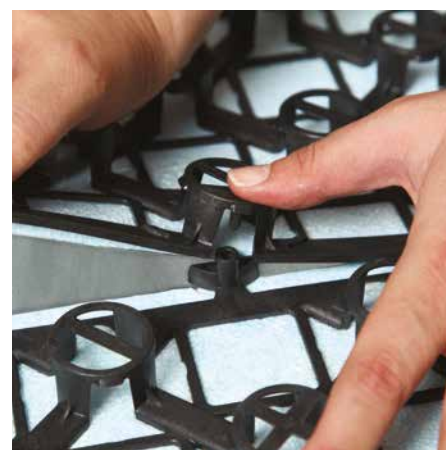



For all screeds described above, **strictly comply with minimum thicknesses and installation techniques specified by the manufacturer's datasheets.**

No electro-welded net required. Start up of the system must be performed according to the instructions specified above.

RADIANT WALL INSTALLATION

The regulation provisions for radiant walls are the same set forth for radiant floors, with the following additions and/or amendments.

The walls must be able to support the radiant system.

The insulation layers required to obtain the minimum thermal resistances can be divided into two layers, based on the conditions of the adjoining room: for

example, with an external wall, one insulation layer will be installed directly behind the radiant system while the second layer will be installed externally (external insulation).

The supply temperature of the radiant wall and/or ceiling must not exceed a maximum value that depends on the material in which the pipe is drowned (e.g. 50 °C for plaster-based plaster).

THE FLOOR SYSTEM BY GIACOMINI IN THE HEART OF YOUR HOUSE

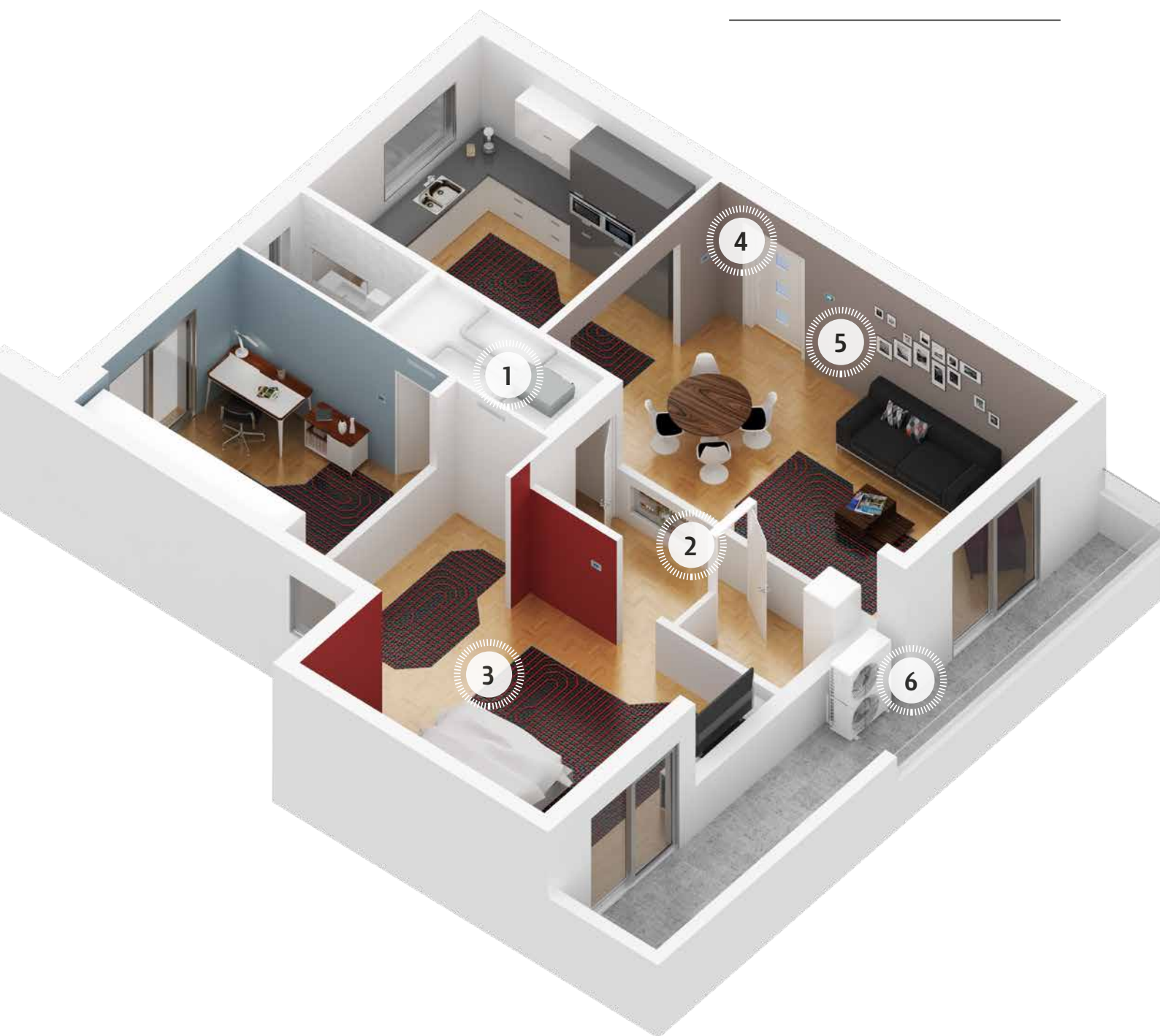

1 - Dehumidifier with air distribution ducts

2 - System manifold

3 - Radiant floor

4 - Room thermostat with humidity sensor

5 - Set-up and control display

6 - Heat pump







GIACOMINI.COM



GIACOMINI S.P.A.
VIA PER ALZO, 39
28017 SAN MAURIZIO D'OPAGLIO
NOVARA ITALY

